

Univerzitet u Novom Sadu - Fakultet tehničkih nauka
REVERZIBILNO INŽENJERSTVO I BRZA IZRADA PROTOTIPA
U BIOMEDICINSKOM INŽENJERSTVU

3D DIGITALIZACIJA
U BIOMEDICINSKOM INŽENJERSTVU
predavanje 4

Prof. dr Igor Budak

Triangulacija strukturiranom svetlošću

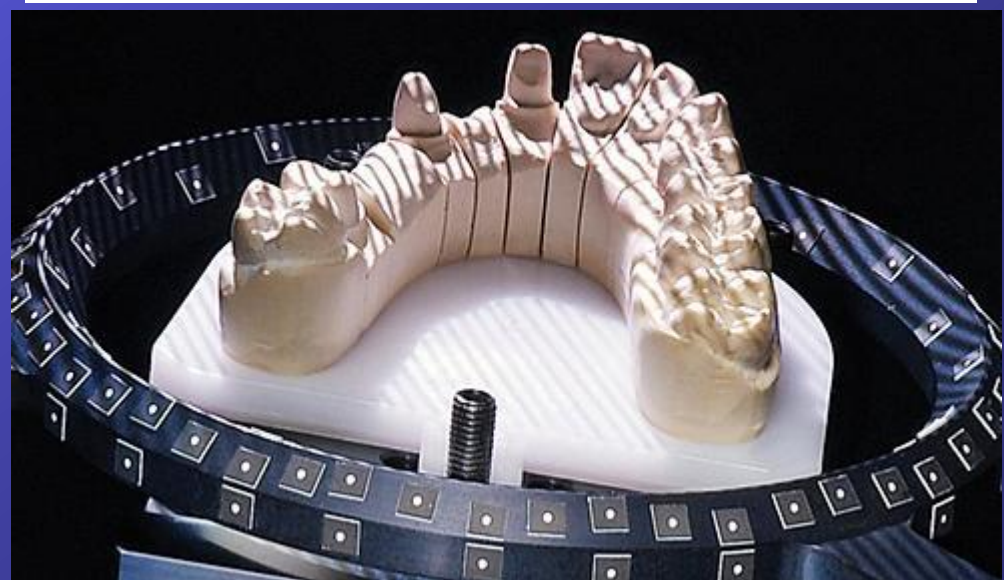
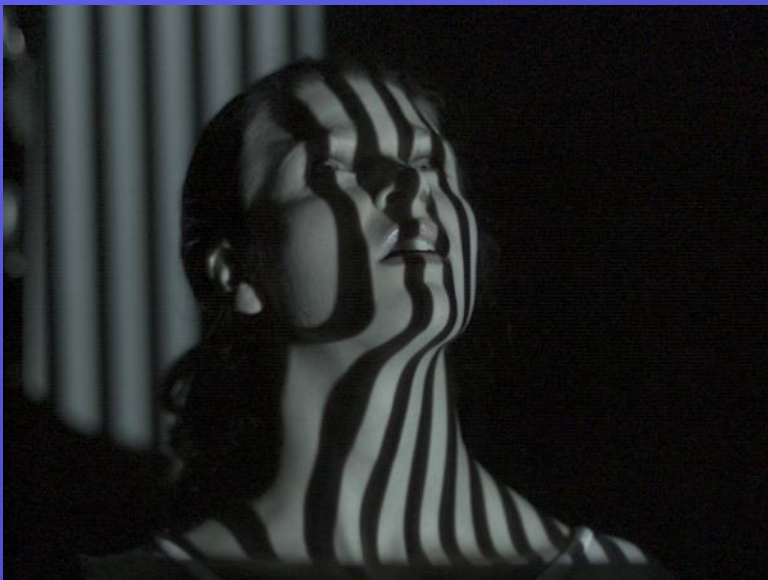
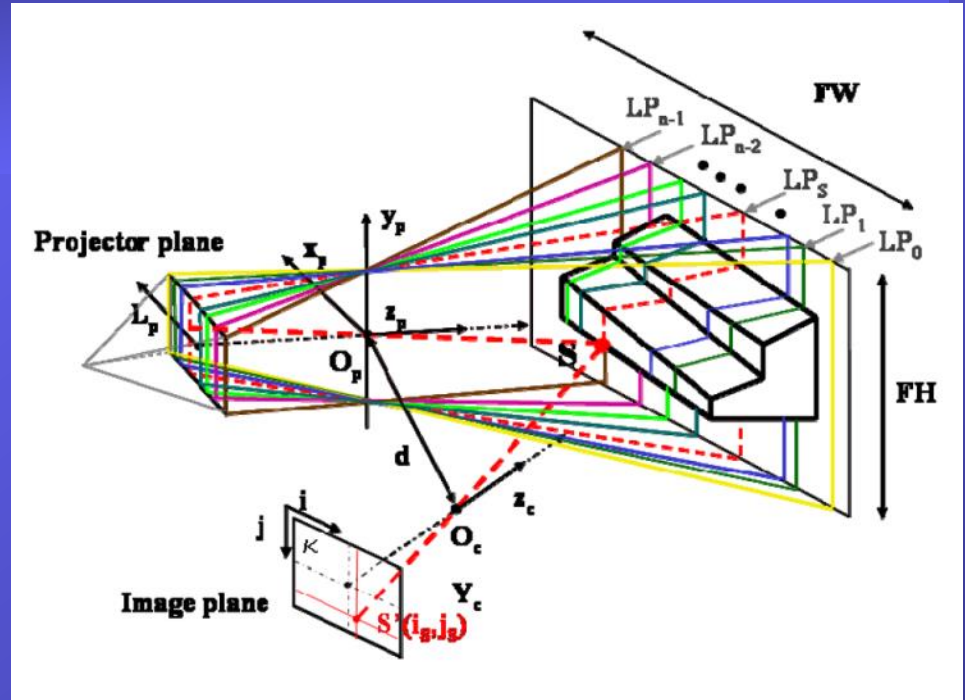
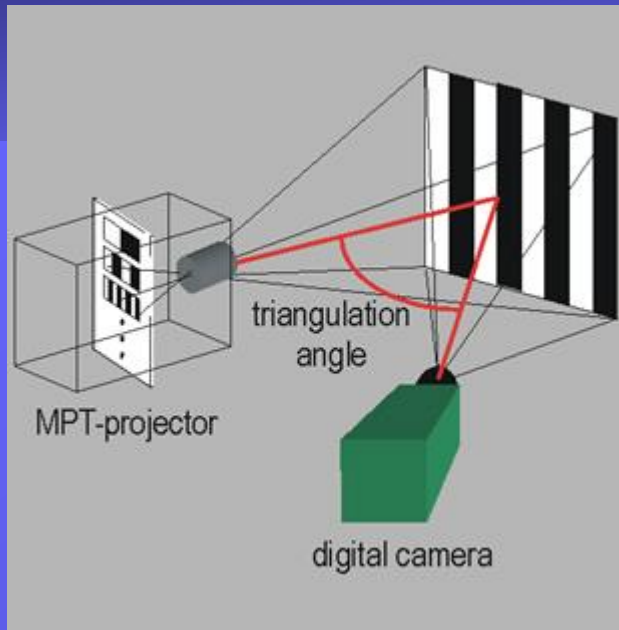

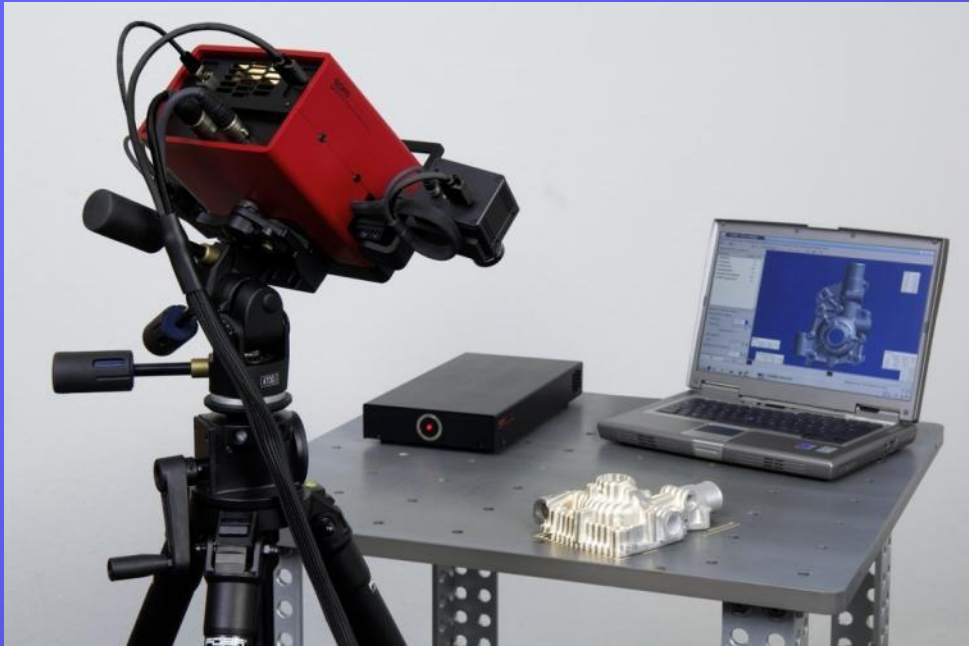

INTRAORALNI SISTEMI ZA 3D-DIGITALIZACIJU

Intraoralni skener
CADENT iTero®

>>>



<<<

CEREC-Connect-Blue-LED

LINIJSKO I POVRŠINSKO SKENIRANJE

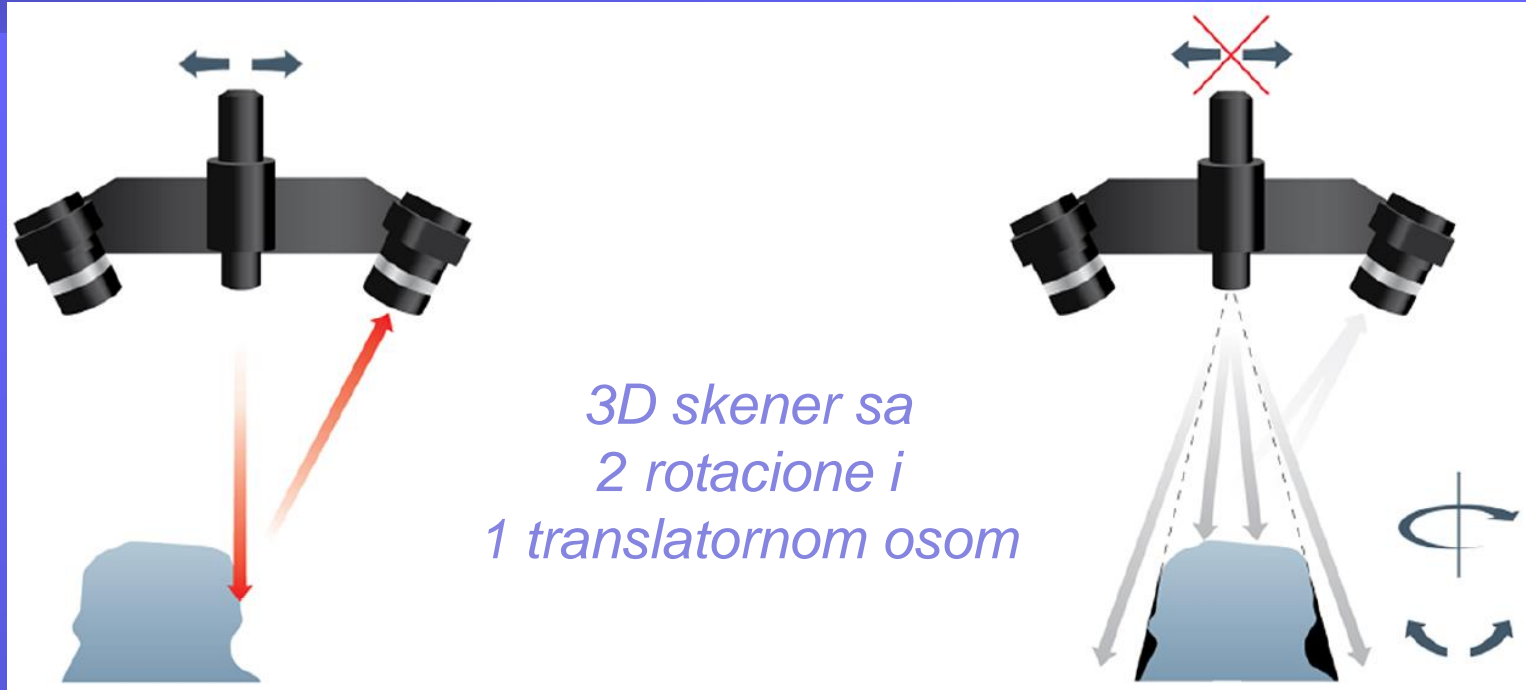

Laser generiše svetlosnu liniju koja se translatorno pomera preko objekta

Izvor bele svetlosti generiše multiplicirane svetlosne linije pokrivajući iz jedinstvene pozicije ceo objekat

Fotogrametrija kao metoda stereovizije

Stereovizijski princip:

Projektovanje dve slike istog objekta, snimljene pod različitim uglovima, omogućuje stvaranje efekta treće dimenzije, tj. dubine.

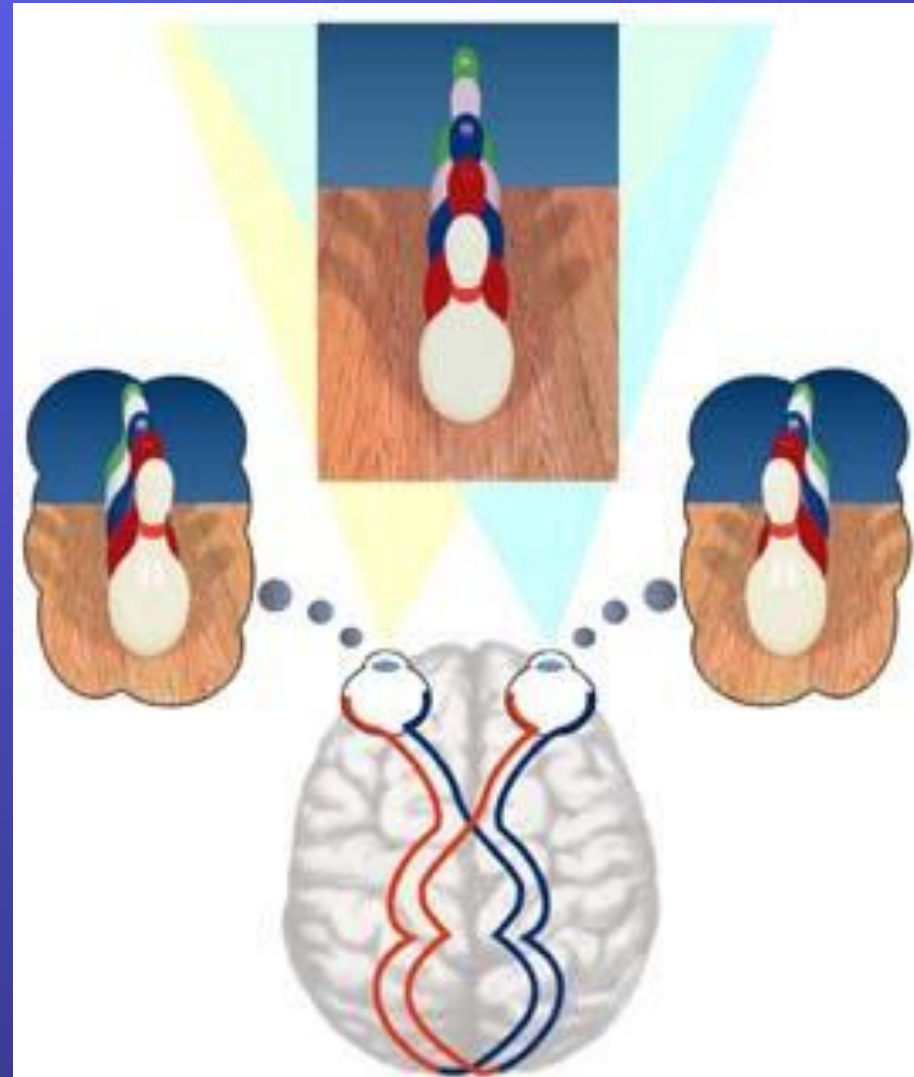

Princip stereovizijske fotogrametrije

Izračunavanje udaljenosti **dodatnih** tačaka

Izračunavanje udaljenosti **referentnih** tačaka

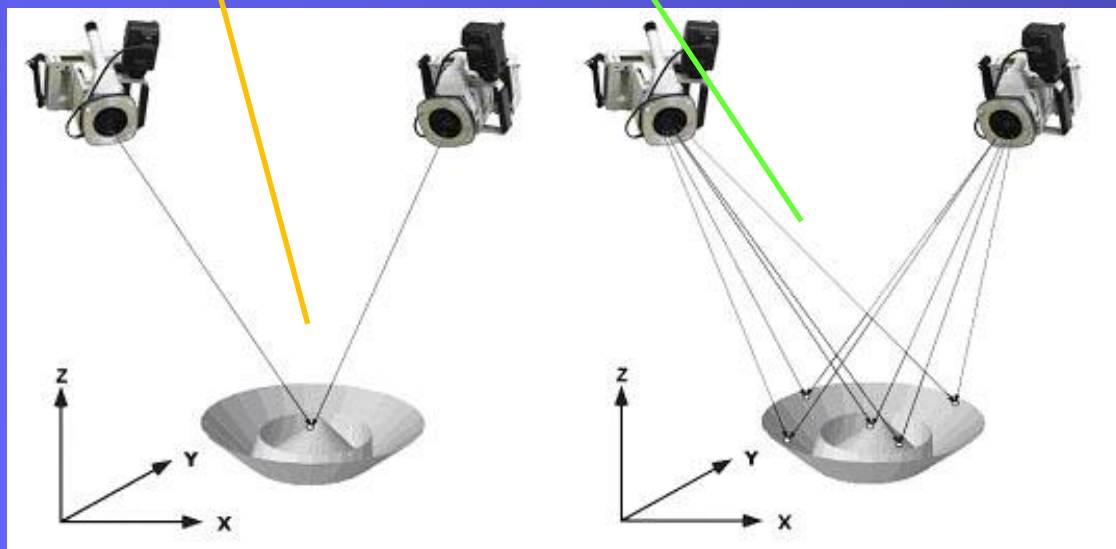
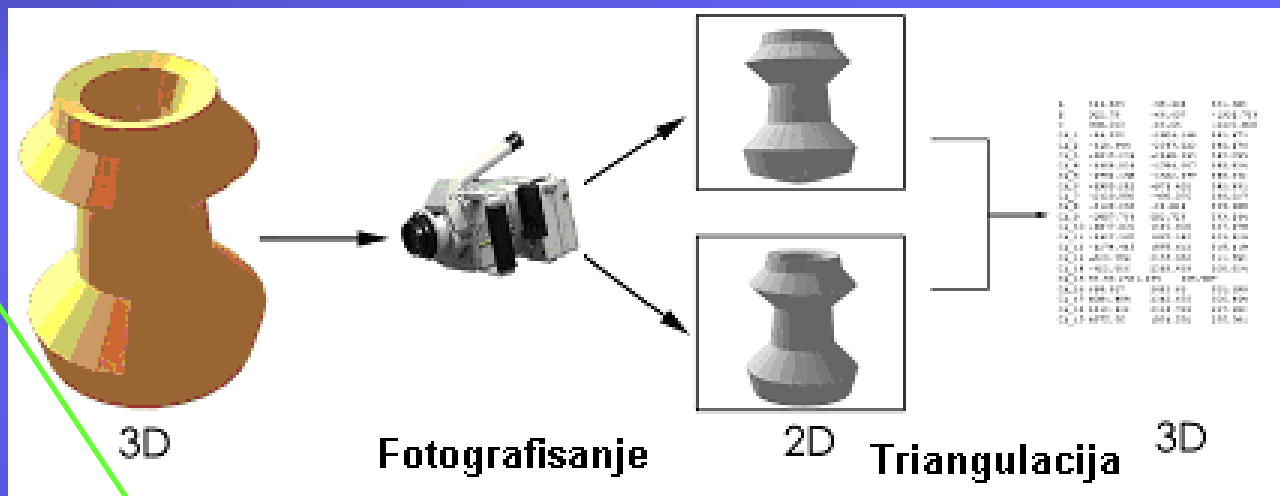

Princip triangulacije kod stereovizije

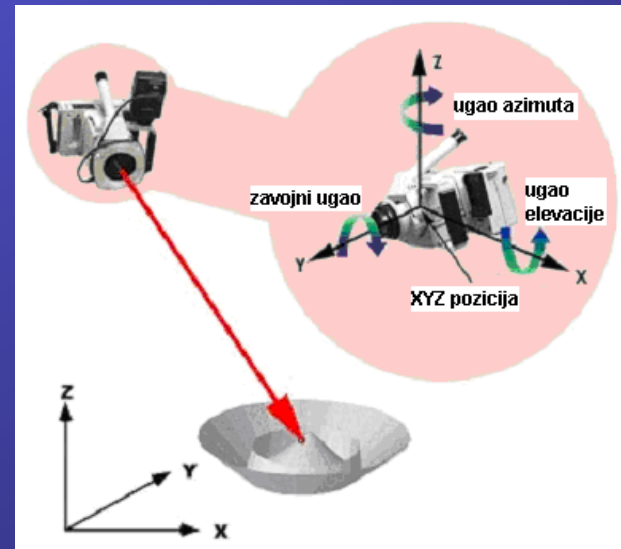

Parametri kamere

Princip stereovizijske fotogrametrije

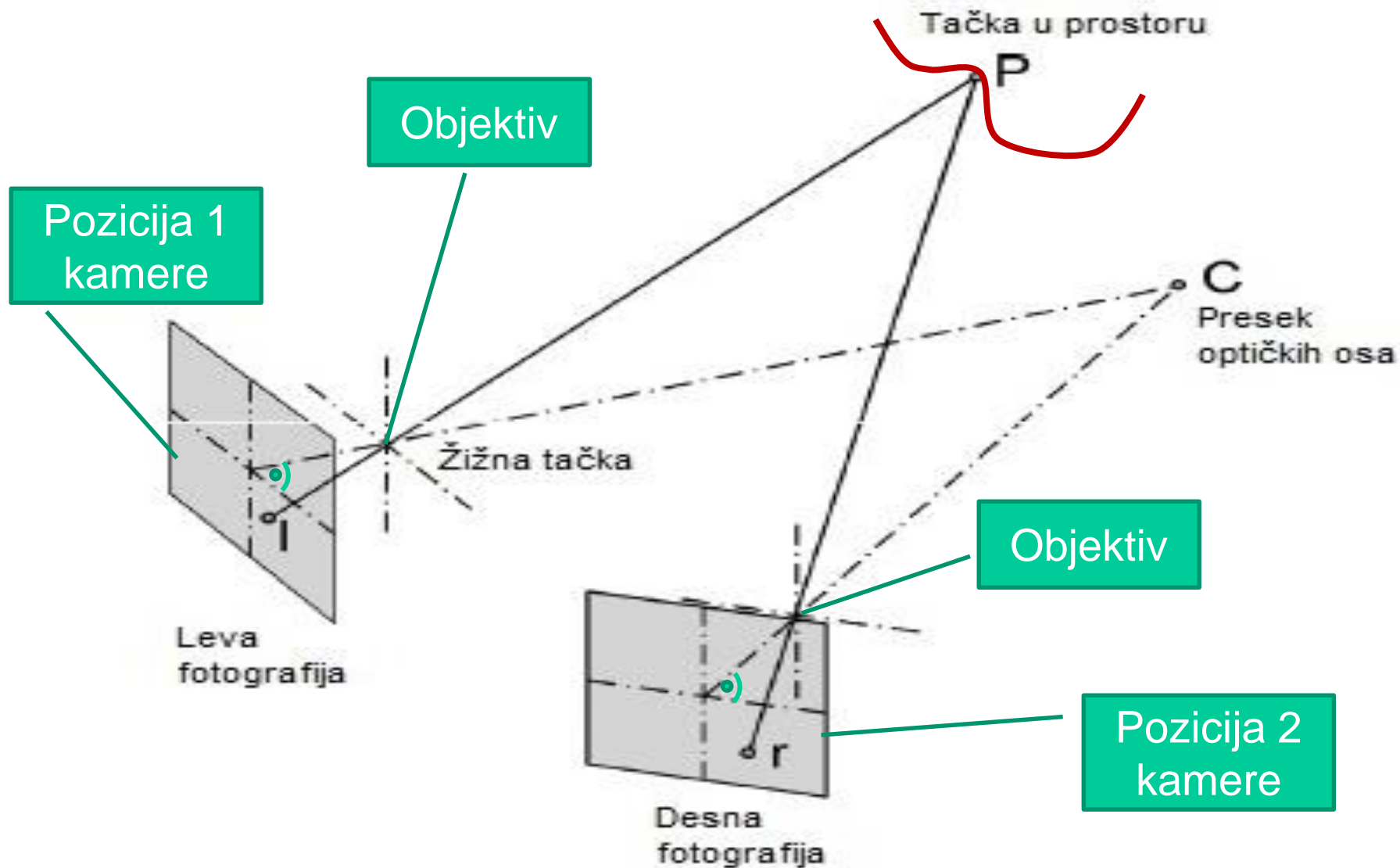

Princip stereovizijske fotogrametrije

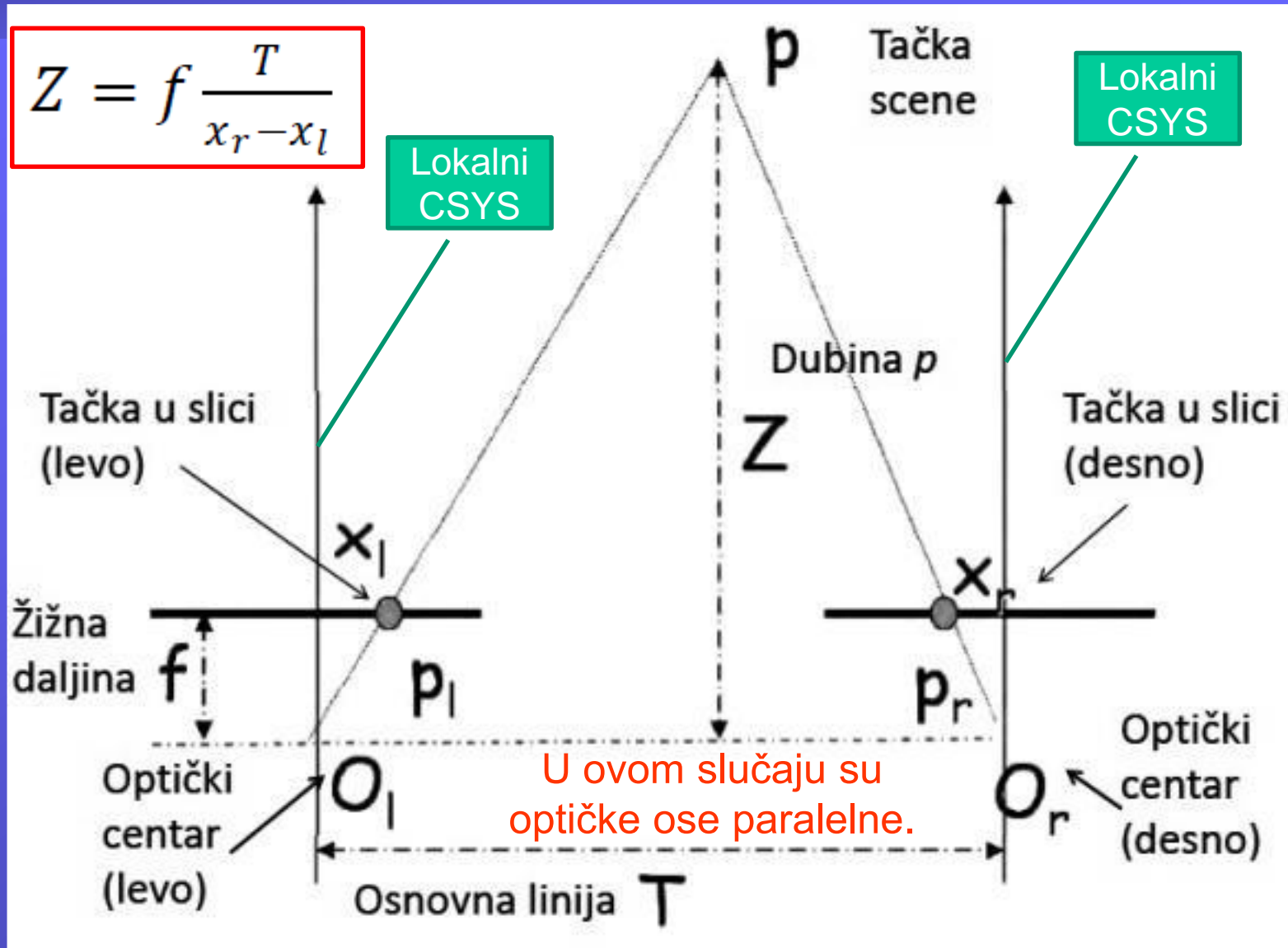

Uticajni faktori na tačnost fotogrametrije

1. Veličina objekta koji se digitalizuje
2. Broj (parova) fotografija
3. Višestruka pokrivenost objekta - preklapanje fotografija (isti delovi objekta vidljivi na 2 i više fotografija)
4. Rezolucija fotografija

Uticajni faktori na tačnost fotogrametrije

Fotogrametrijska piramida tačnosti



Piramida tačnosti



Skaliranje modela

Dva pristupa za skaliranje (dimenzionisanje) 3D modela:

- 1) preko dimenzionisanih obeležja na predmetu i
- 2) pomoću kodiranih markera.

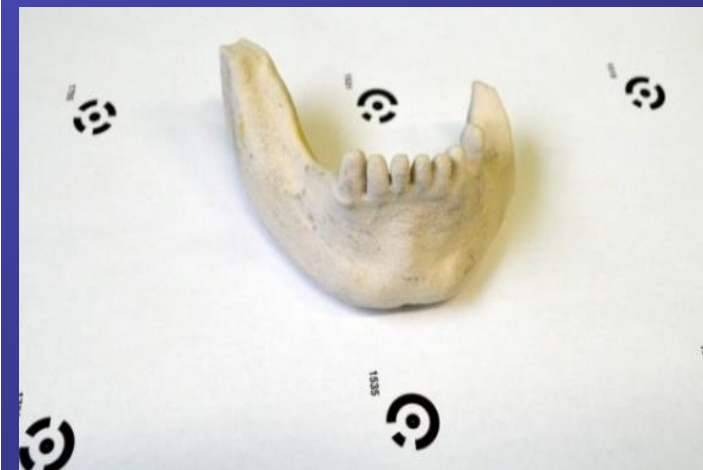
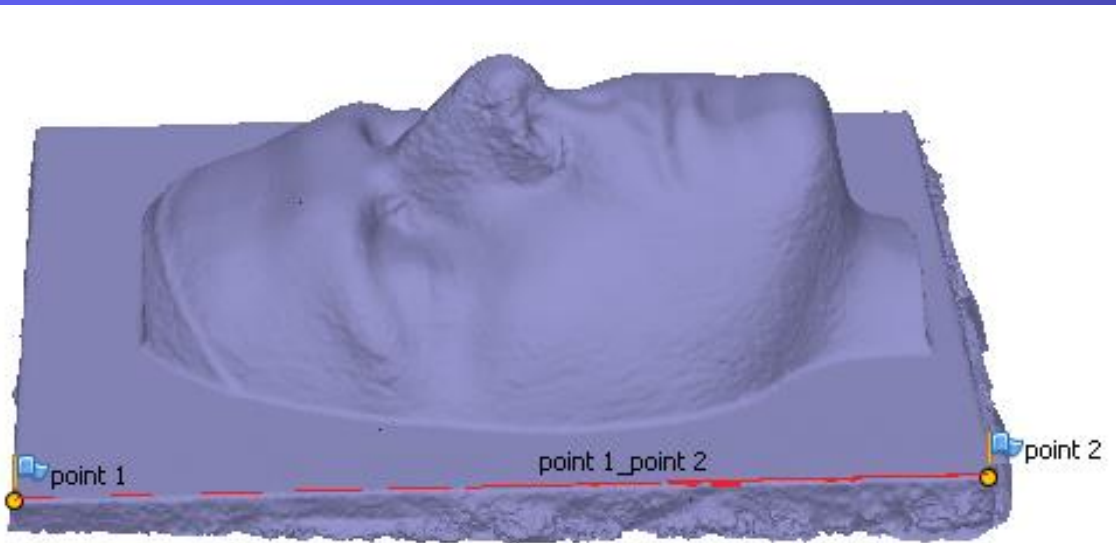
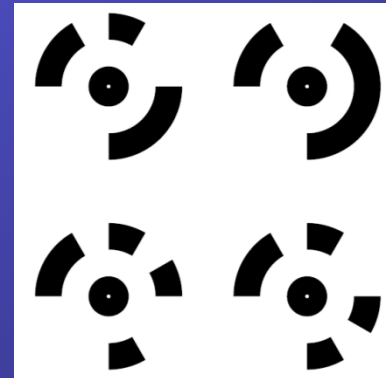

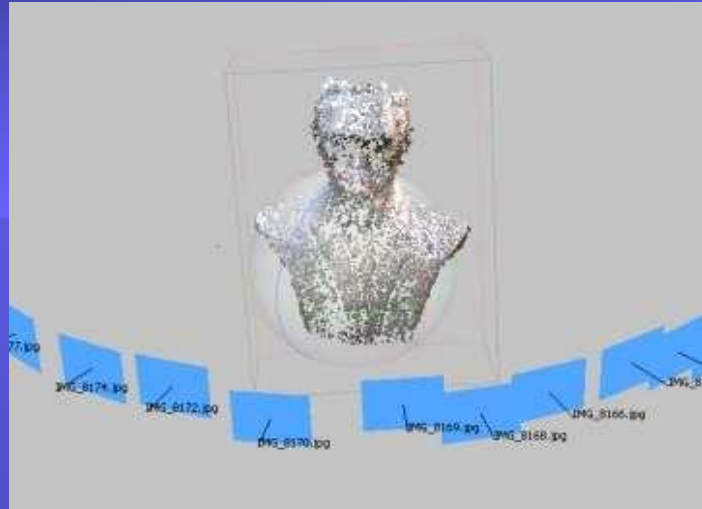
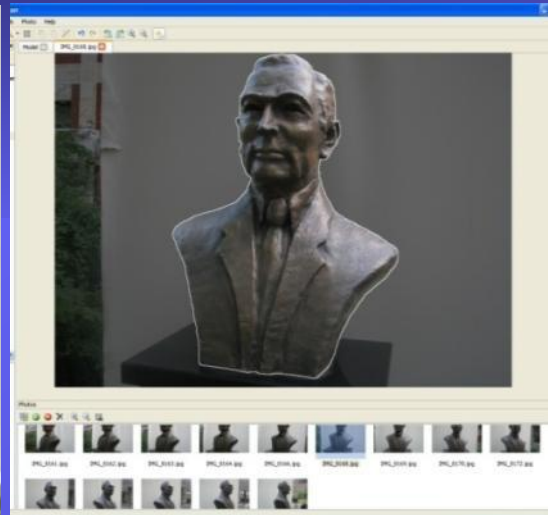

3D model sa teksturom >>>

3D model>>>

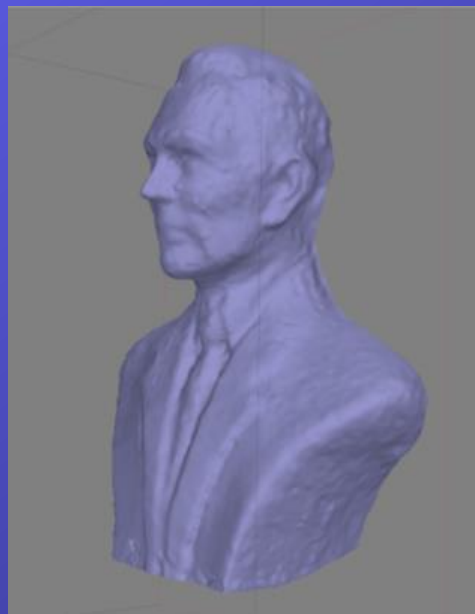

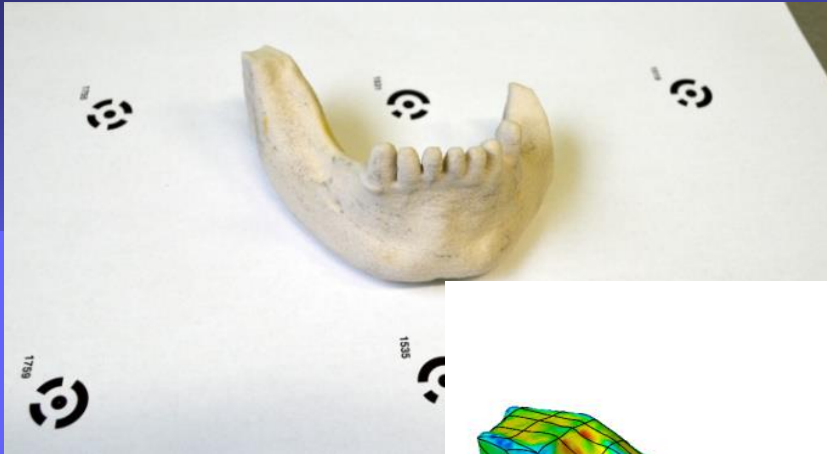

Model ljudske vilice postavljen u model

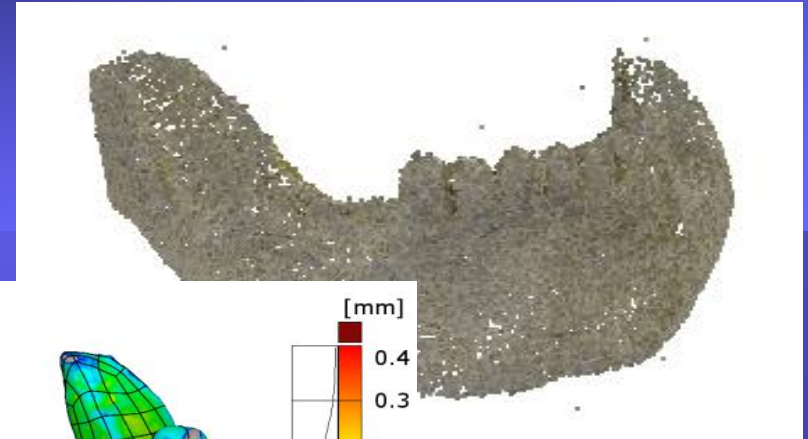

Rezultat poravnavanja fotografija

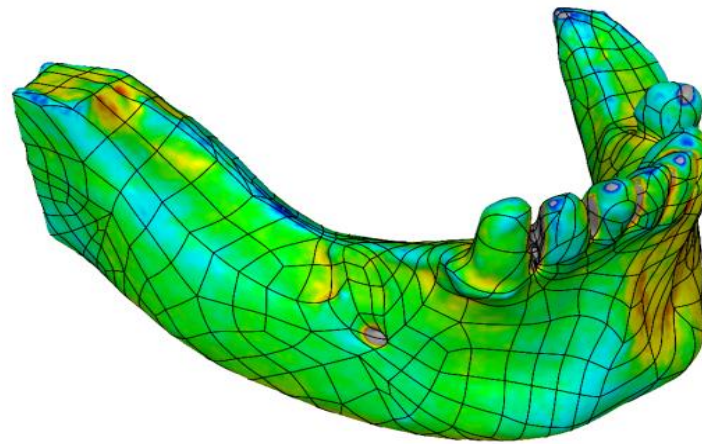

Analiza odstupanja CT i fotogrametrijskog modela

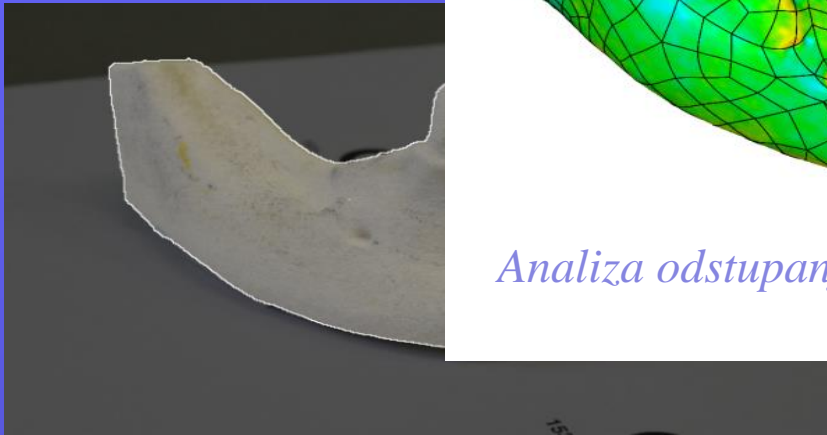
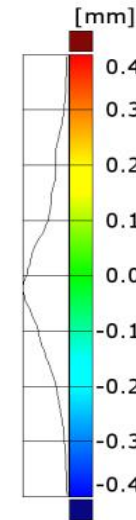

Primer dobro kreirane maske

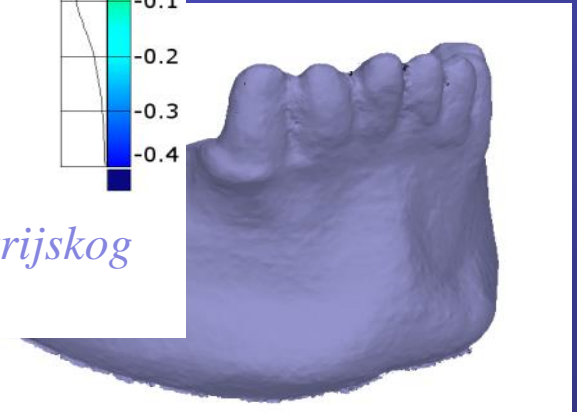

3D model kreiran fotogrametrijskom metodom

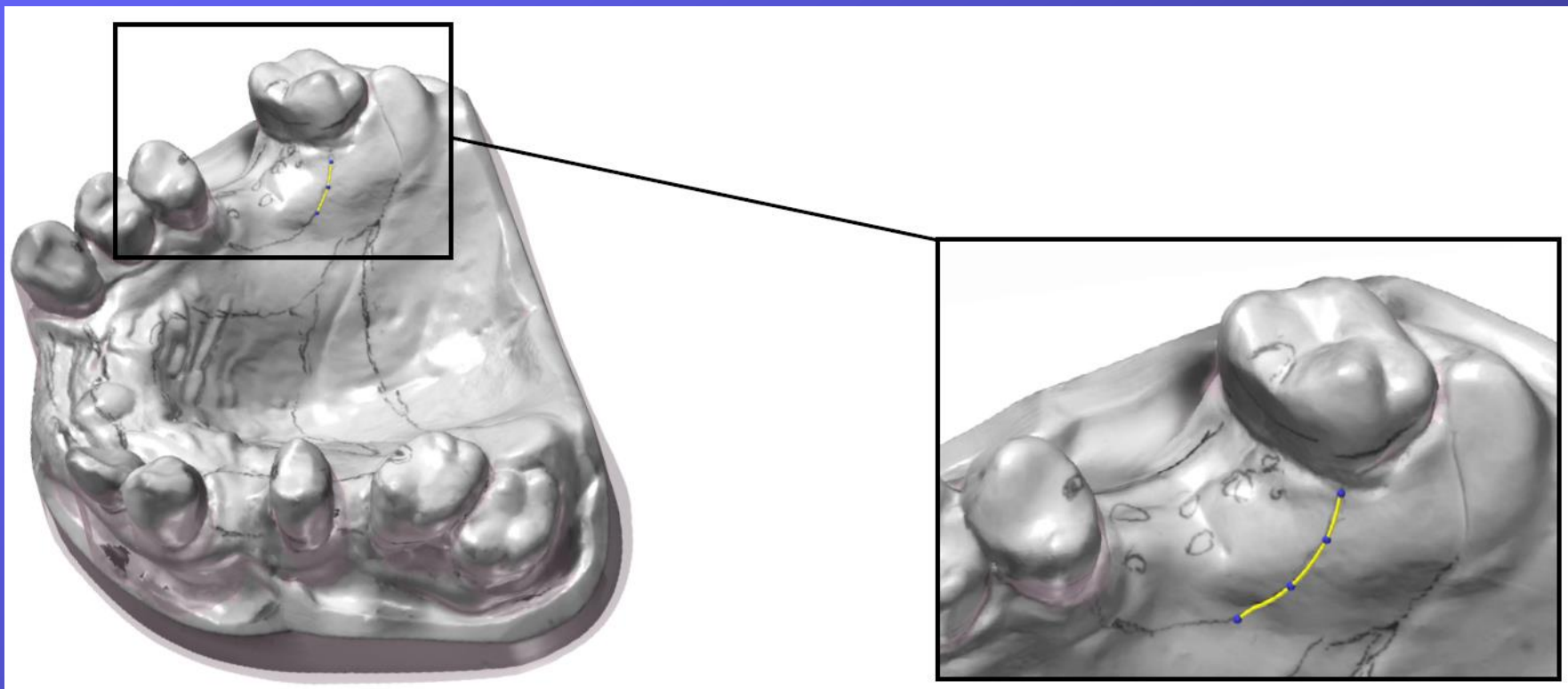
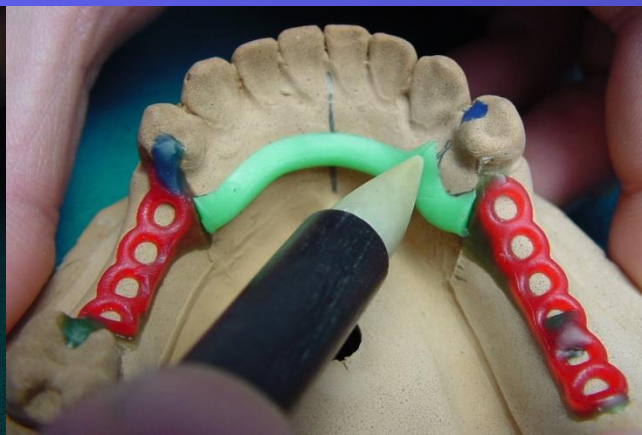
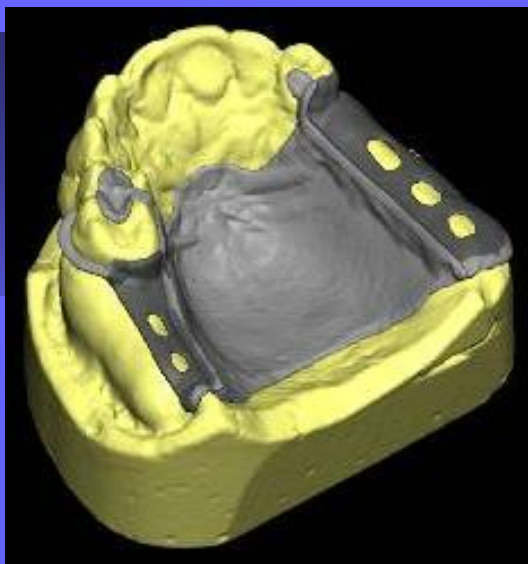

Acquisition



Without pattern

Random pattern

Wavelet pattern



3D models generation

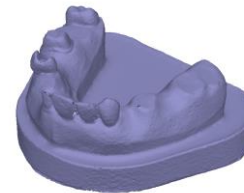
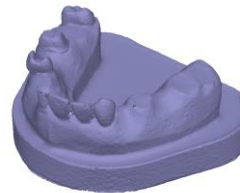
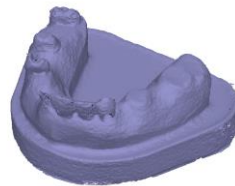

Nominal 3D model



CAD inspection

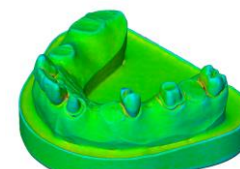
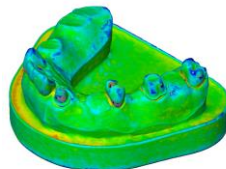

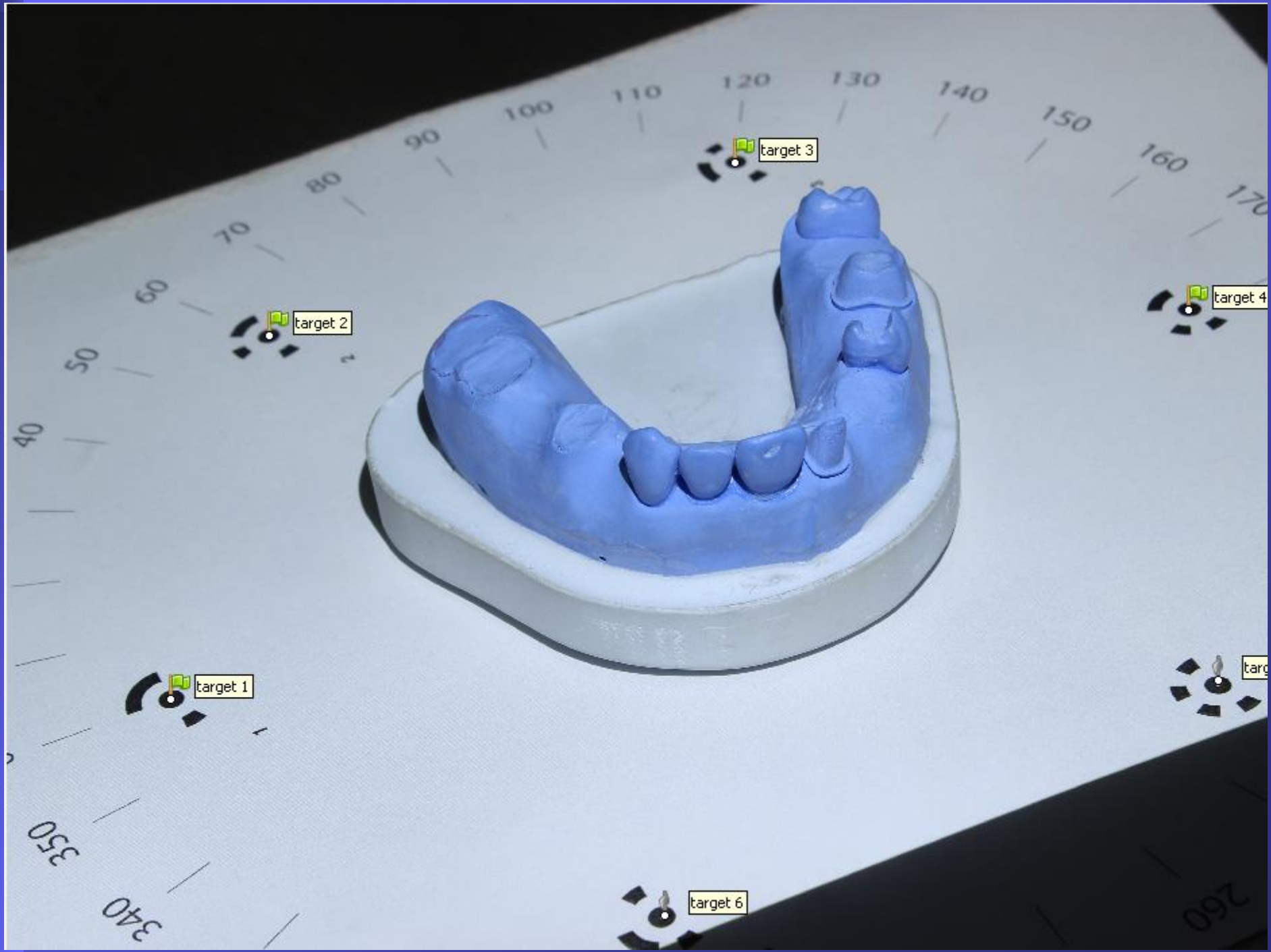

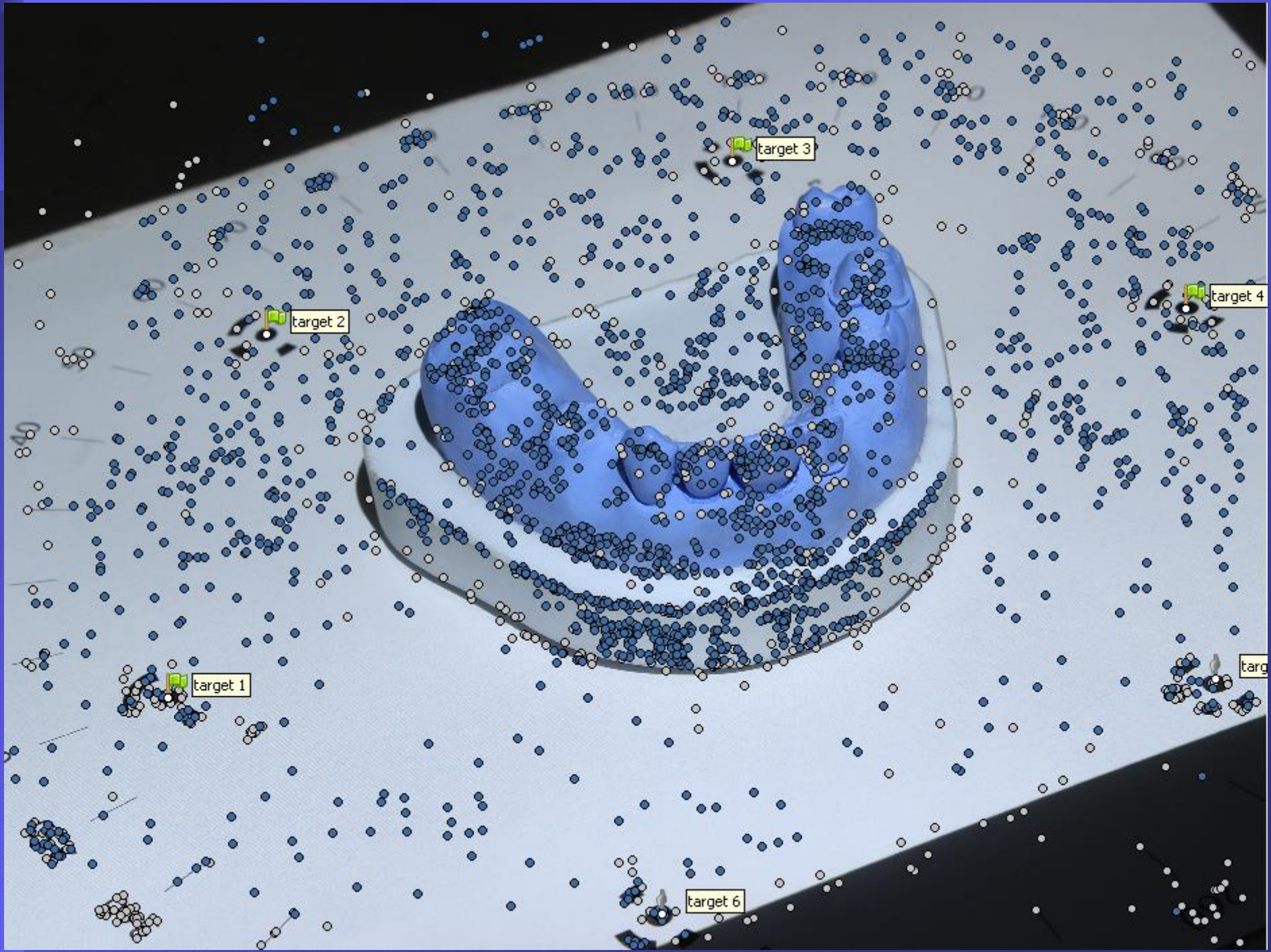

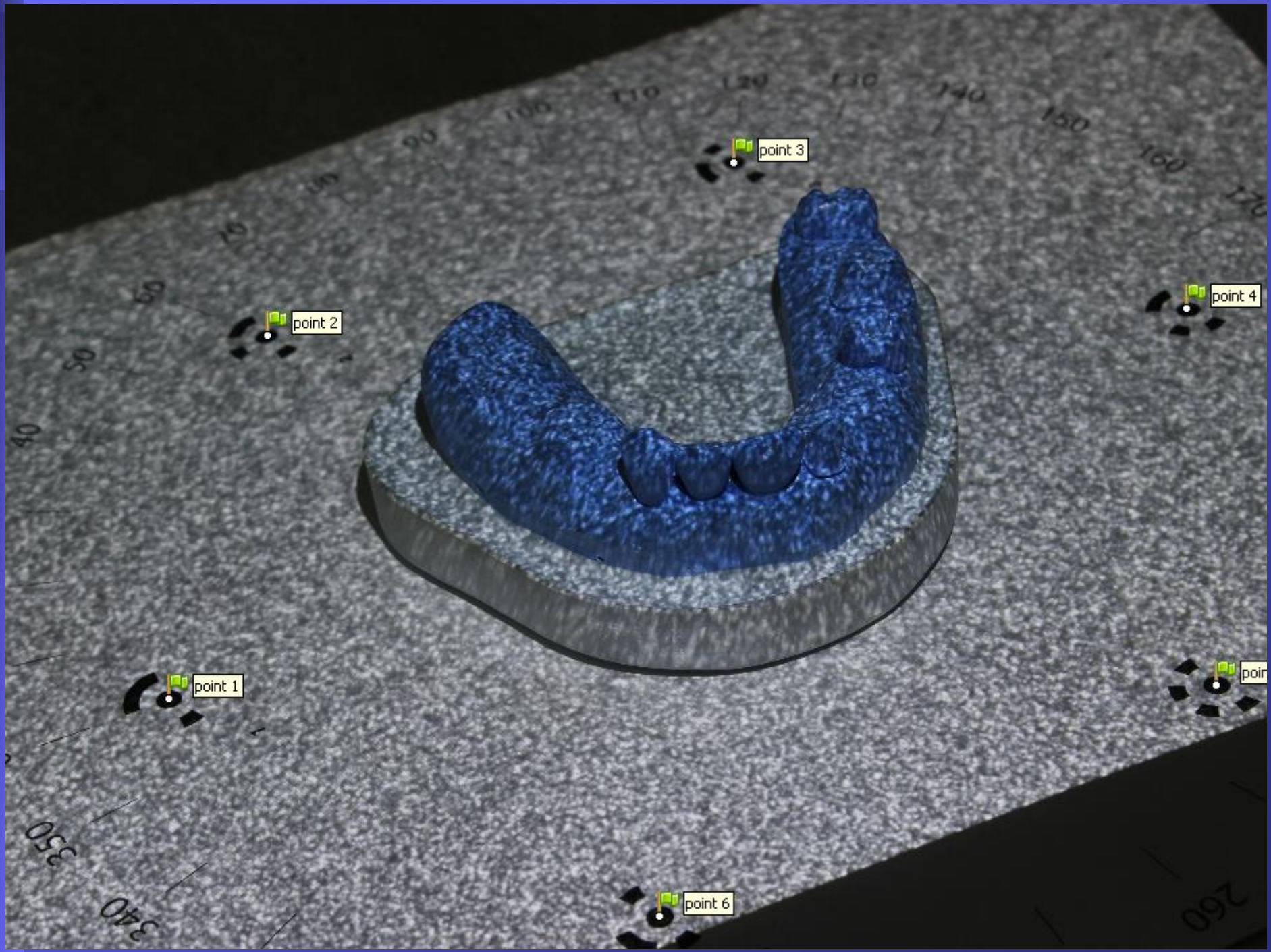

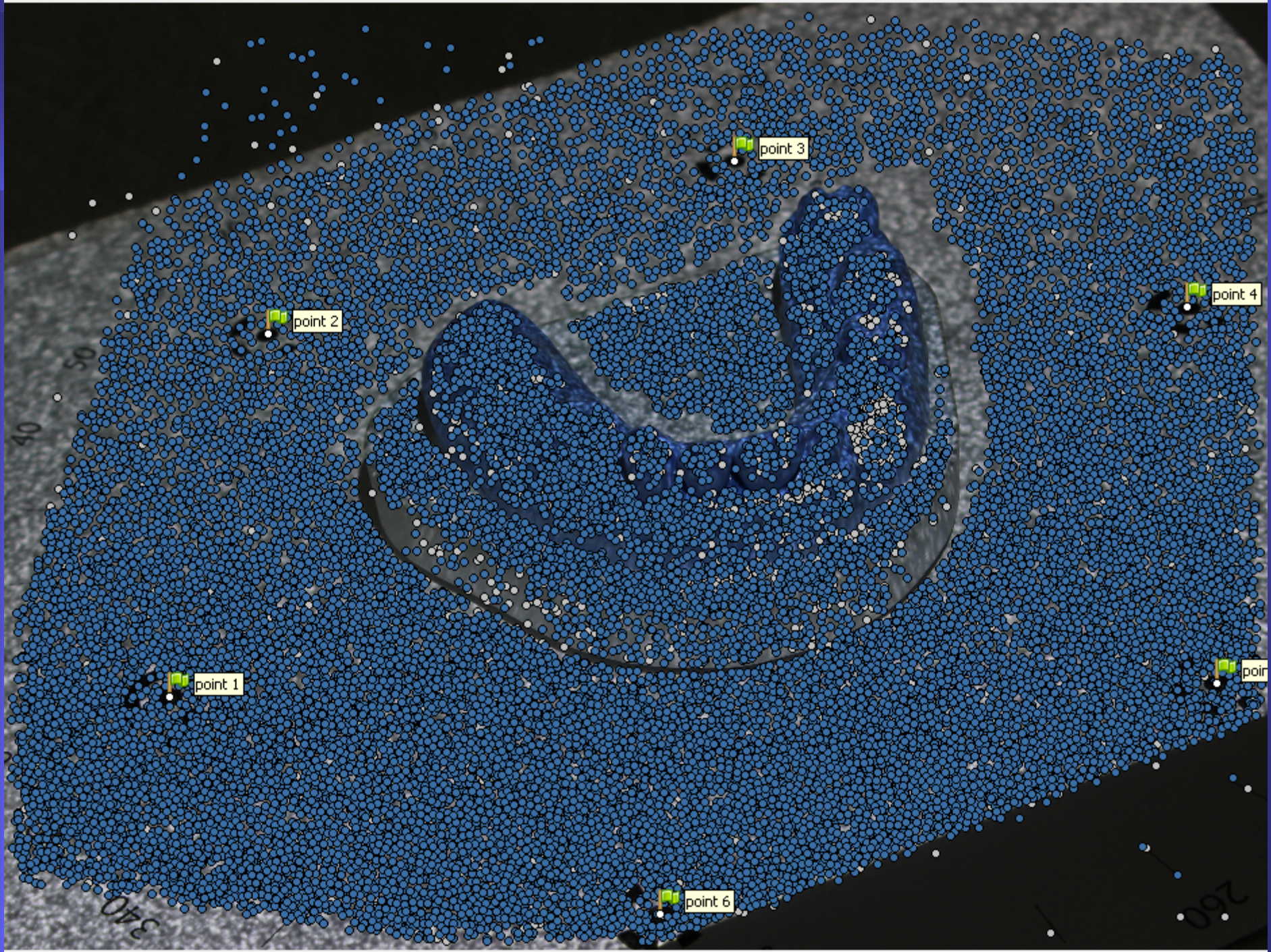

METODOLOGIJA REVERZIBILNOG INŽENJERSTVA

3D digitalizacija

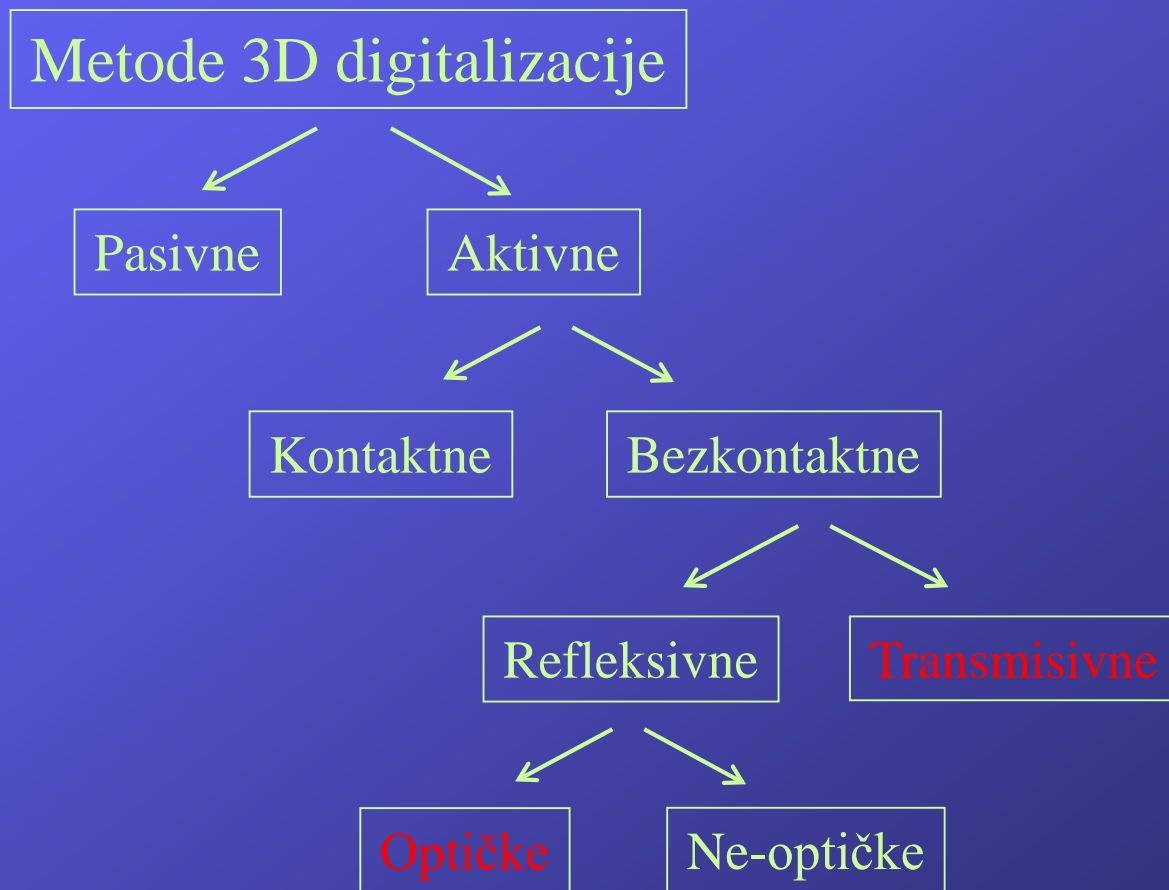

Transmisivne metode za 3D digitalizaciju

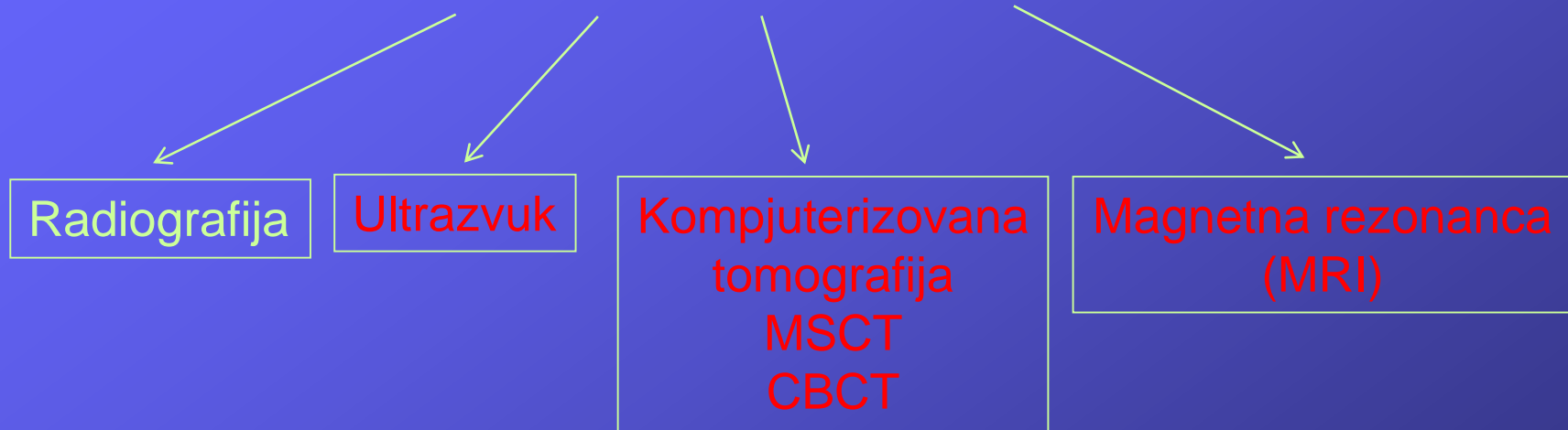

Transmisivne metode detektuju slabljenje signala (najčešće energetski) nakon prolaska kroz mereni objekat, odnosno mere količinu energije koju objekat nije apsorbovao.

Kompjuterizovana tomografija

Kompjuterizovana tomografija



```
graph TD; A[Kompjuterizovana tomografija] --> B["Multi-slajs kompjuterizovana tomografija (MSCT)"]; A --> C["Kompjuterizovana tomografija sa konusnim snopom (CBCT)"];
```

Multi-slajs
kompjuterizovana tomografija
(MSCT)

Kompjuterizovana tomografija
sa konusnim snopom
(CBCT)

Kompjuterizovana tomografija

Pri prolasku kroz materijal dela, X-zraci atenuiraju (slabe) usled apsorpcije ili rasejavanja;

Nivo atenuacije zavisi od:

- ❑ dužine puta koji prelaze unutar apsorbirajućeg materijala,
- ❑ strukture materijala i njegove gustine (odnosno atenuacionog koeficijenta μ) i
- ❑ energije X-zraka.

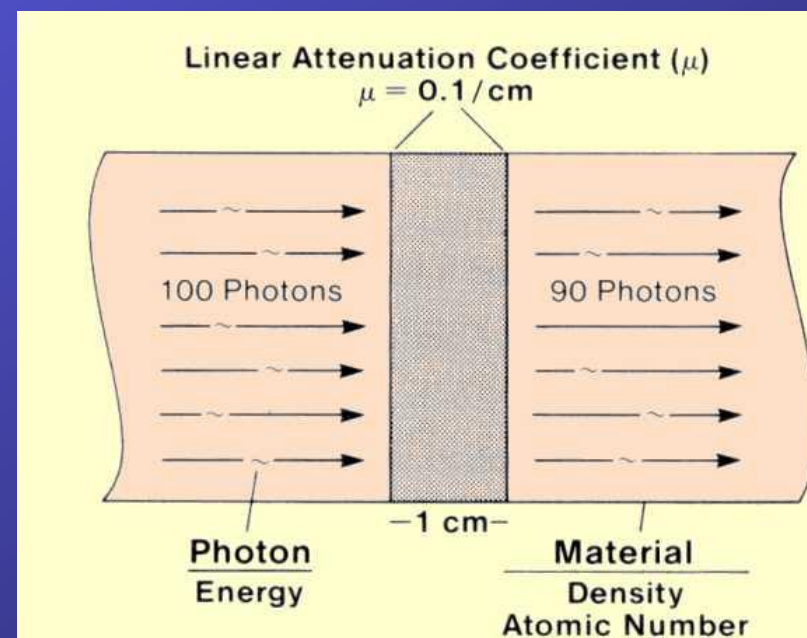

Atenuacioni koeficijent materijala ograničava max. debljinu materijala koja može biti probijena.

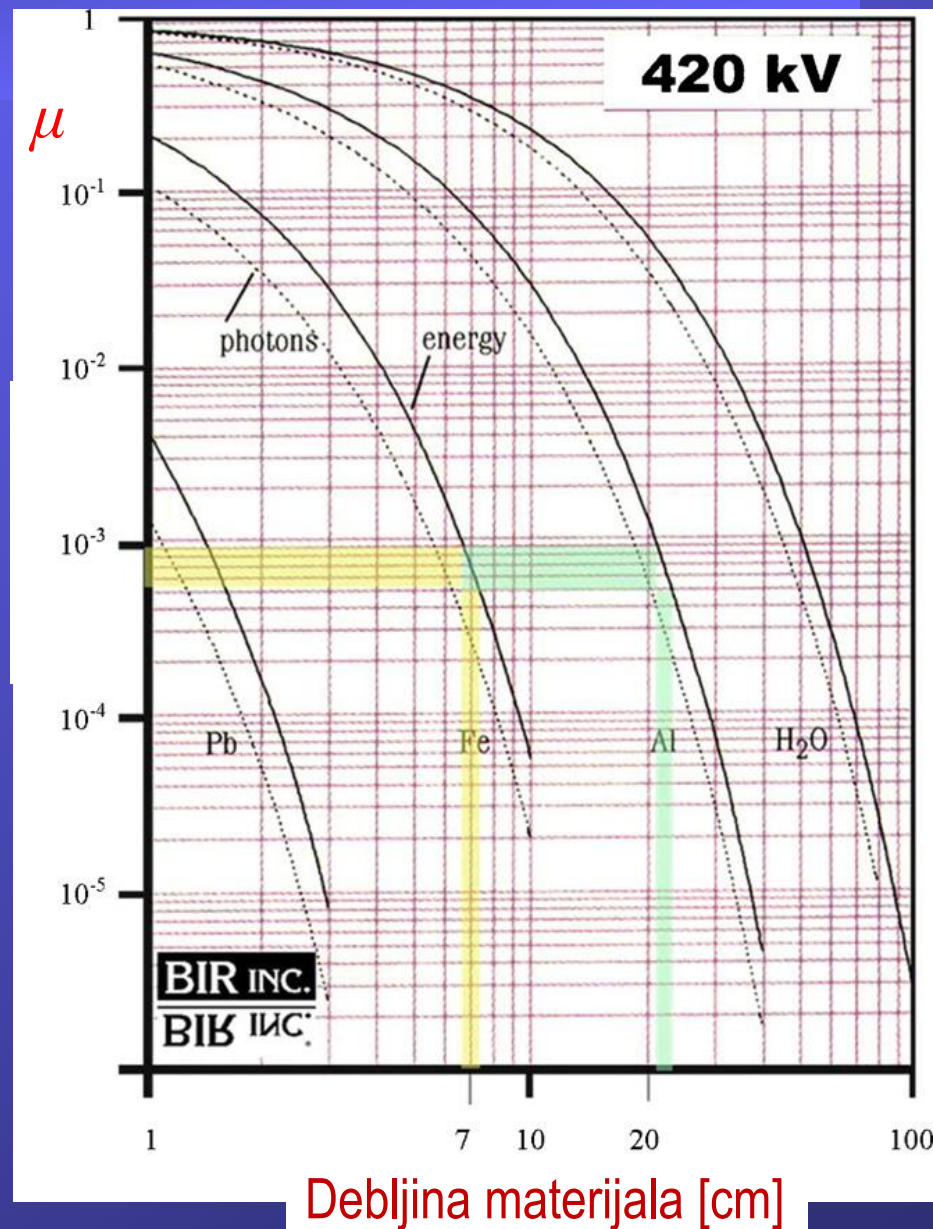

CT je jedina tehnologija pomoću koje je moguće 3D digitalizovati objekte sa nedostupnim unutrašnjim površinama:

- proizvodi proizvedeni **aditivnom proizvodnjom (3D štampa)**;
- proizvodi od više materijala (MMC - multi materila components):
 - dvo-komponentni proizvodi od plastike i
 - plastični delovi sa umetcima od metala;



Multi-slajs kompjuterizovana tomografija (MSCT)

Generator X-zraka

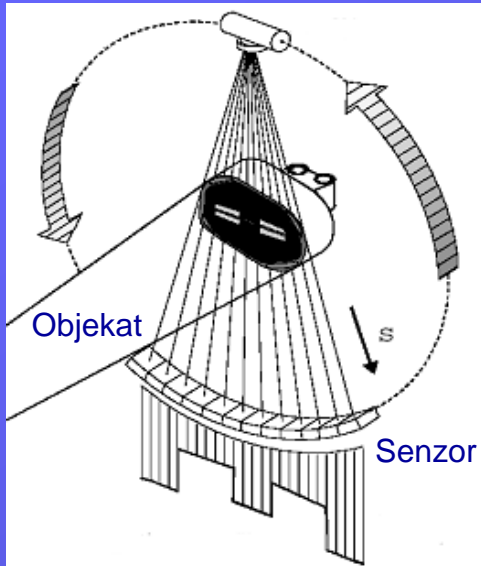

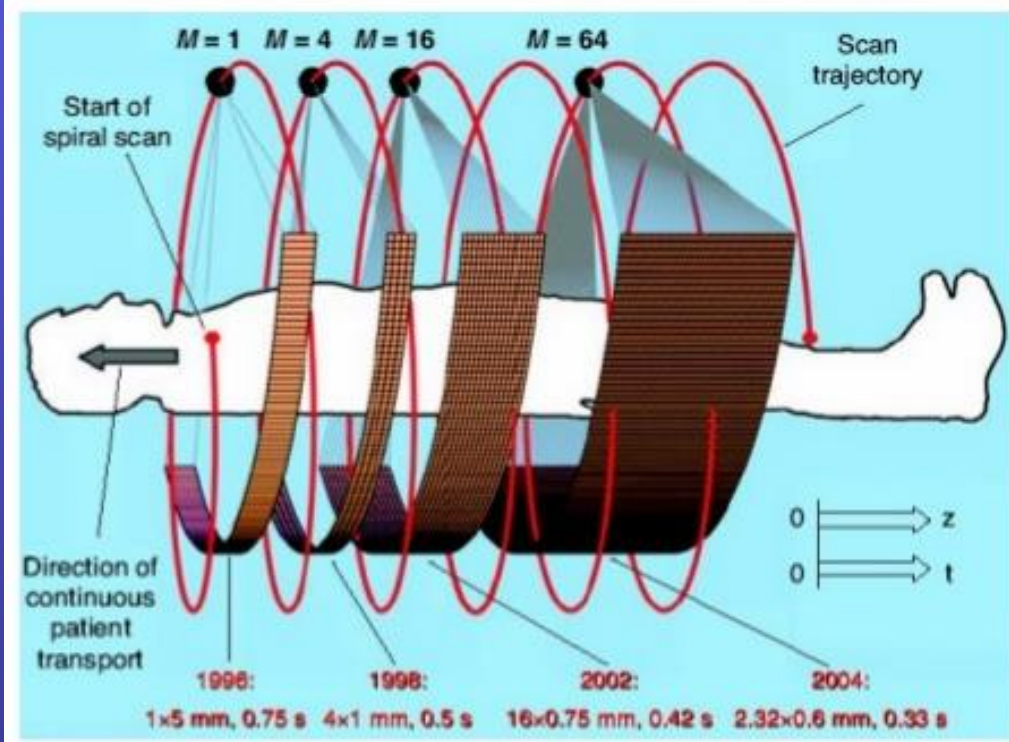
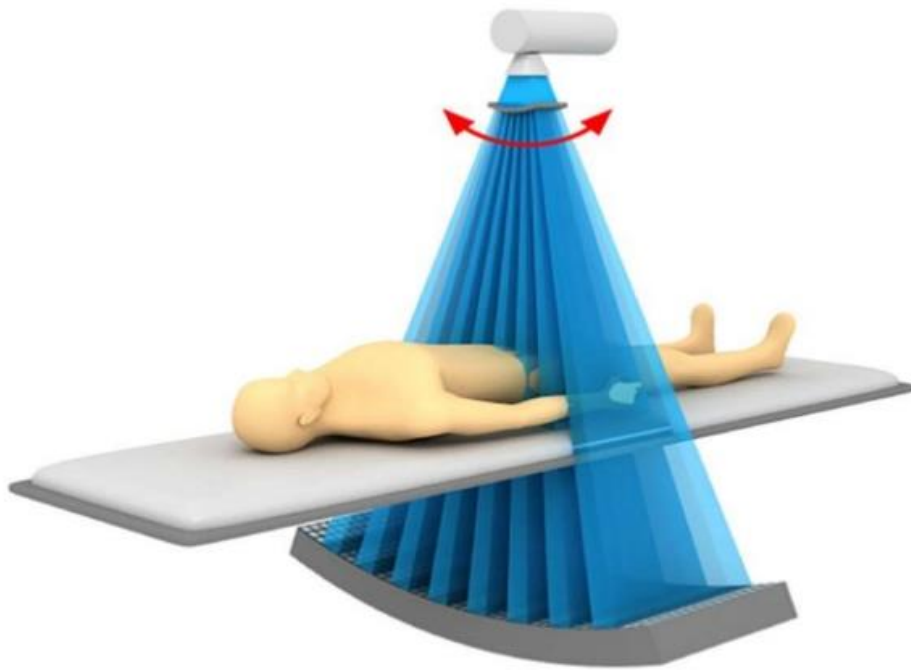

Kompjuterizovana tomografija sa konusnim snopom (CBCT)

Princip rada

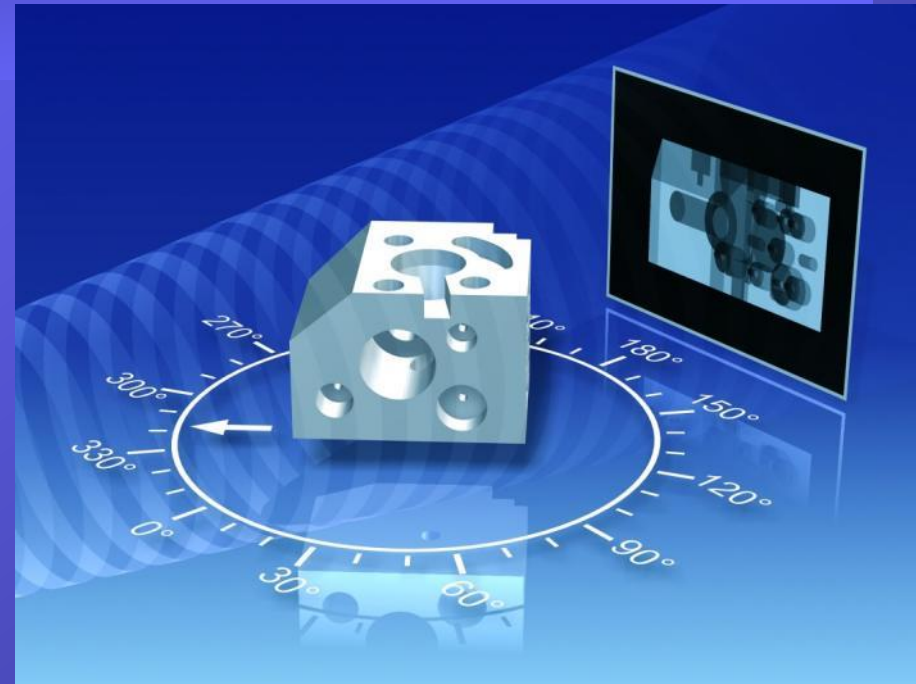
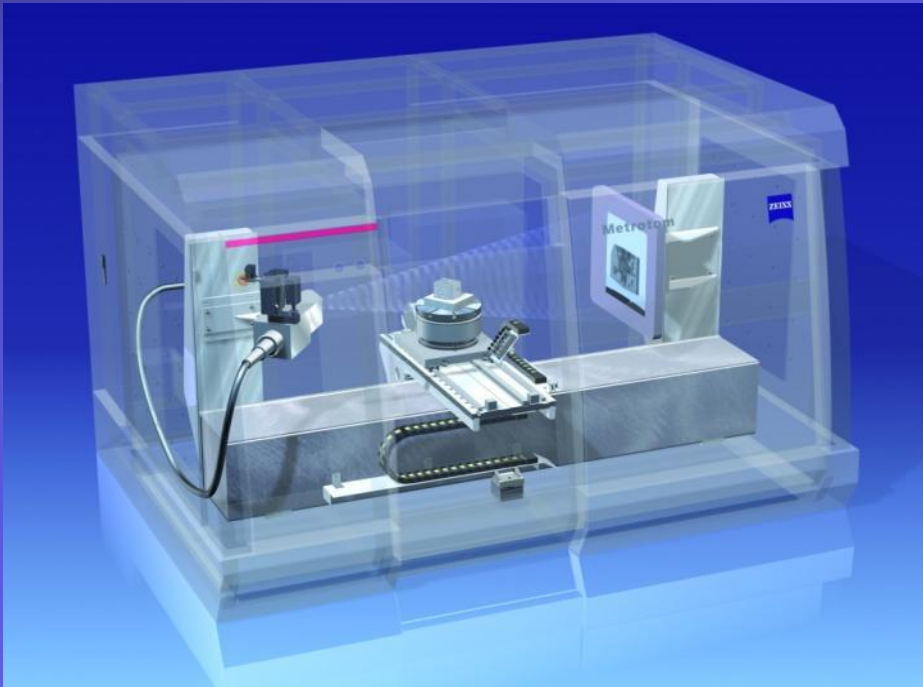

CBCT je u SAD počeo da se primenjuje od 2001. i do 2010. godine je u rad pušteno preko 3000 sistema.

Zeiss Metrotom



Kompjuterizovana tomografija sa konusnim snopom

Princip rada

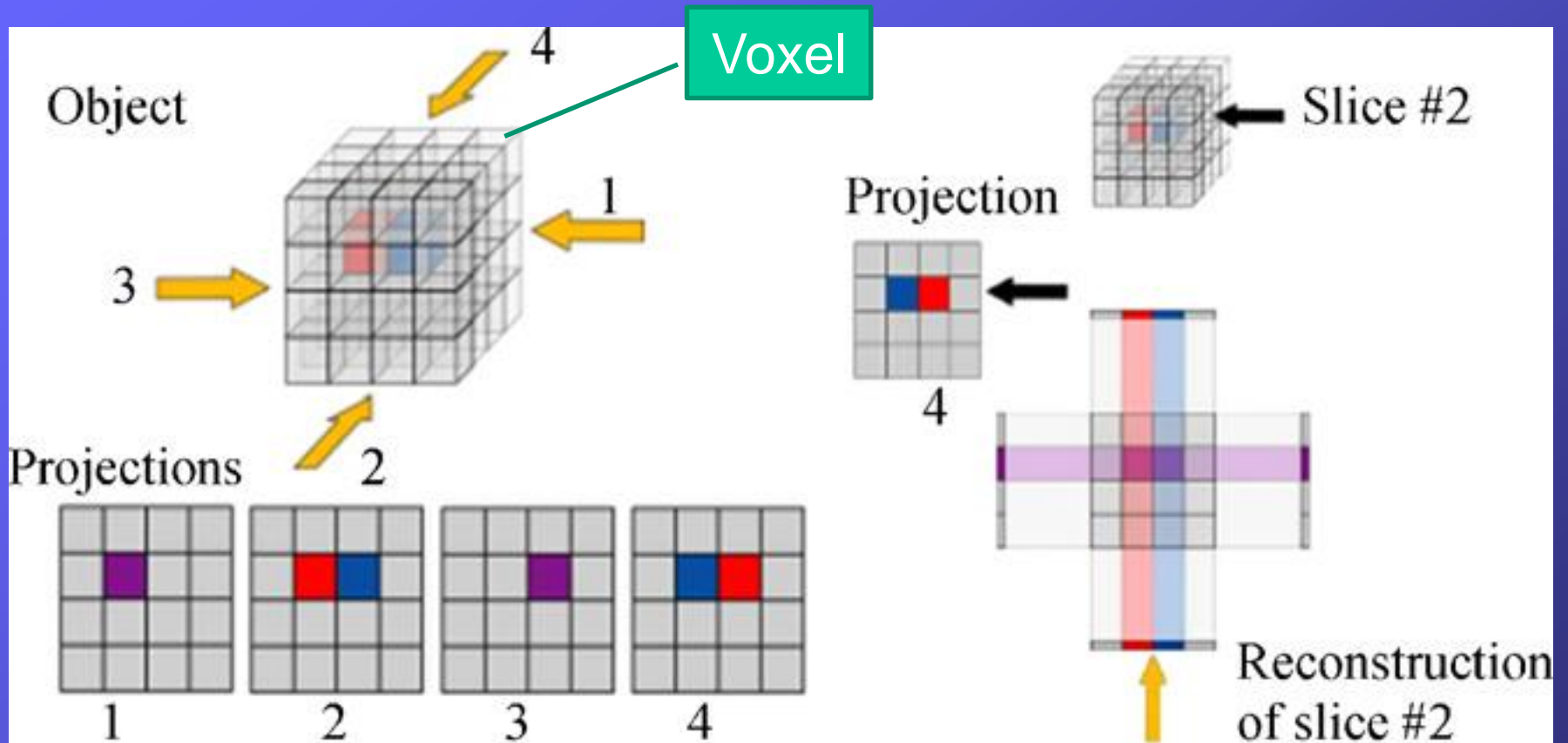

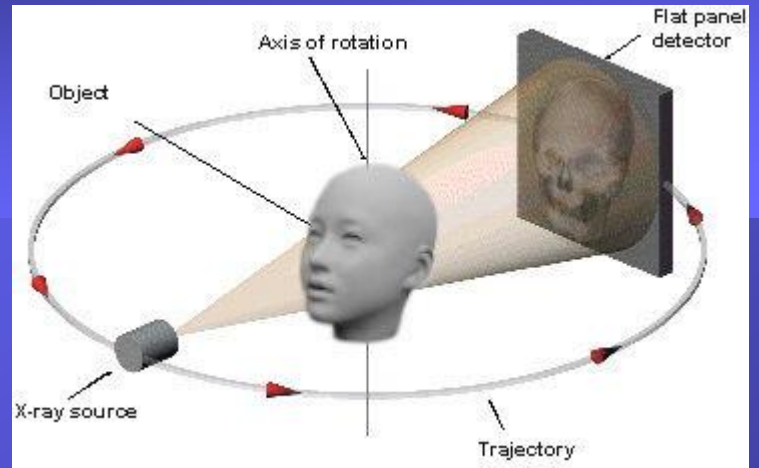

Dentalni CBCT Soredex Scanora 3D

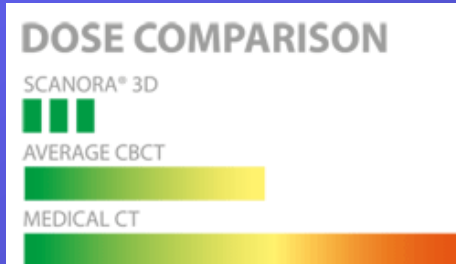

Dentalni CBCT i-CAT



Segmentacija

Nakon što se izvrši skeniranje i dobiju se CT slojevi (poznati kao DICOM slike) vrši se rekonstrukcija kontura slojeva u CT slojevima, za šta se koriste softveri sa rutinama za automatizovano pronalaženje ivica - segmentaciju.

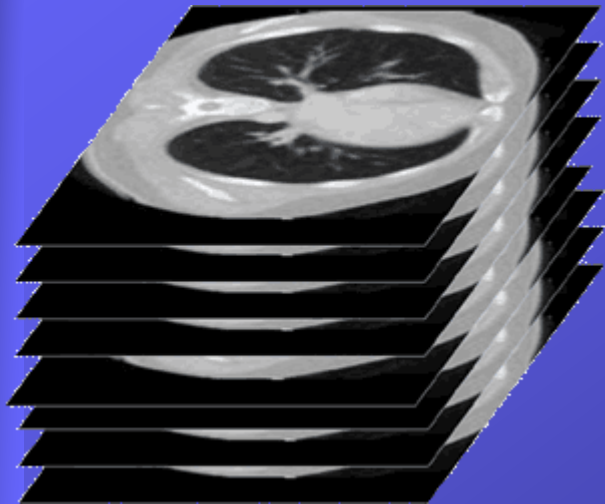

DICOM slike

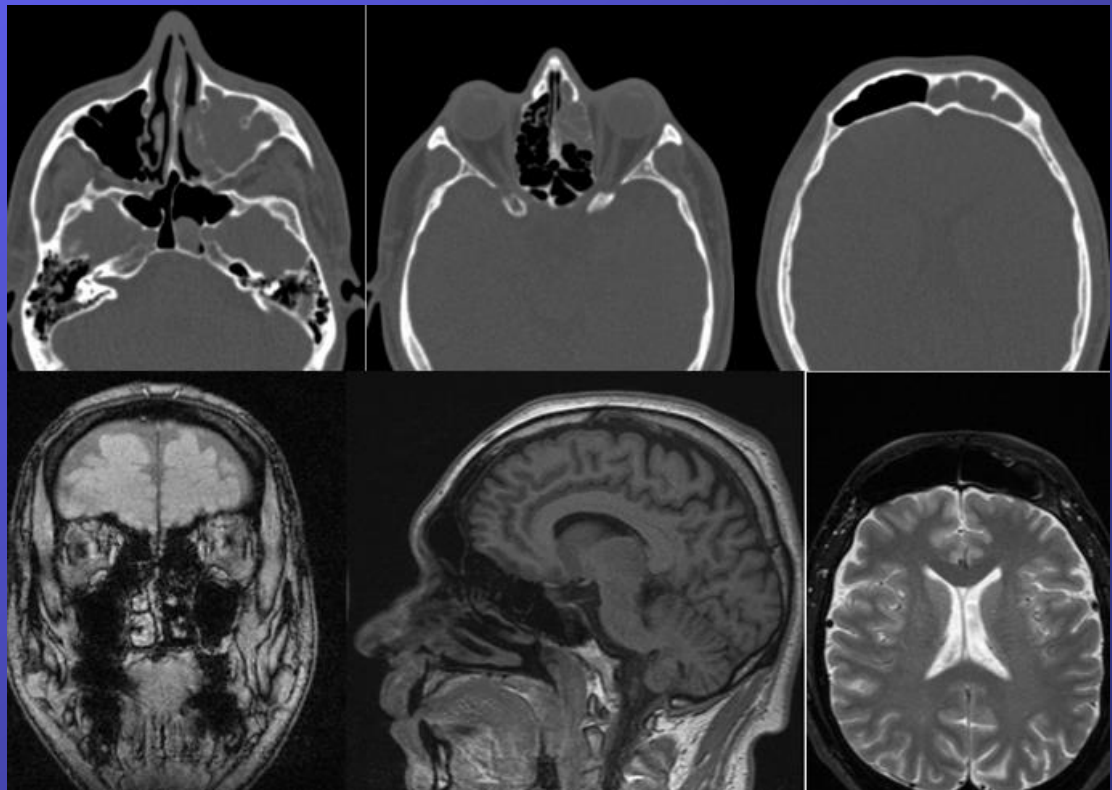

Segmentacija

Thresholds: definisanje dijapazona obuhvaćenih nijansi sivih boja

The screenshot shows the Able Software 3D-DOCTOR interface. The main window displays a large axial CT scan slice with a red segmented mask. A grid of smaller slices is visible on the right. An 'Interactive Segmentation' dialog box is open, showing 'Image Thresholds' set to 1211 and 4096, a color bar, and various options for boundary type and segmentation planes.

File Edit View Image 3D Rendering Window Help

HeadCTHalf0001.lst

40

16 17 18 19 20 21 22 23

24

24

31

32

39

40

47

48

55

56

53

64 65 66 67 68 69 70 71

Interactive Segmentation

Image Thresholds

1211 Use Calibrated Value Refresh 4096

Color Show Image Prev Thresholds

Boundary Type

Outline Only All Boundary Lines Skeleton Boundary

Segment Image Planes

Segment All Segment Plane Prev Plane Set Object

Smooth Image Delete Plane Seg Next Plane Finish

Use Connectivity

(245.60,0.00,40.00)

For Help, press F1. Right mouse button for quick options.

Hounsfield Units

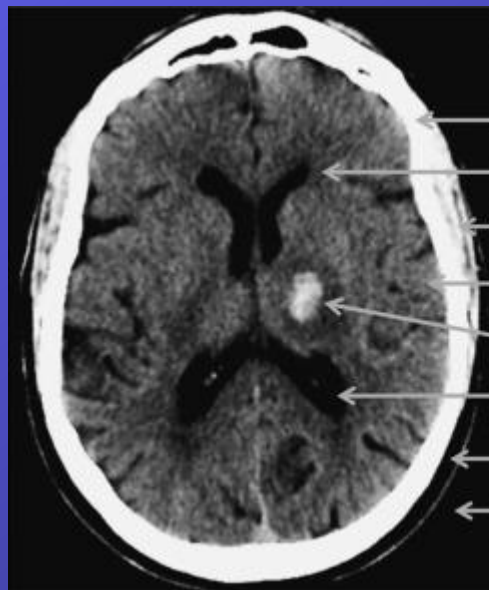
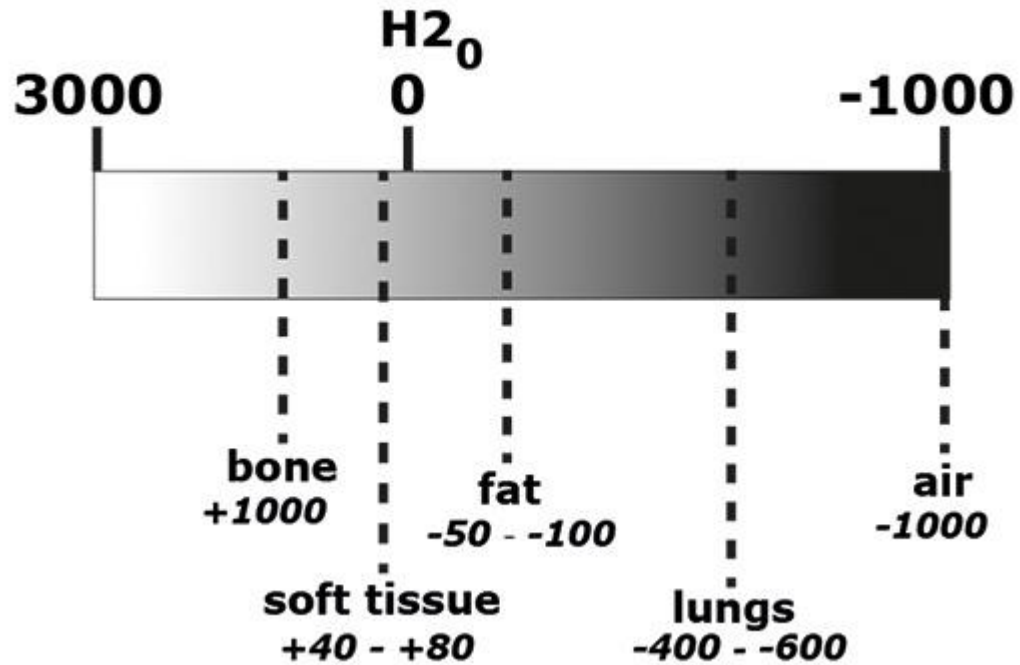

CT Number Ranges in Hounsfield Units (HU)	
Bone	+1000
White matter	+20 to 30
Muscle	+20 to 40
Gray matter	+30 to 40
Hemorrhage	+65 to +95
CSF (water)	0
Fat	-30 to -70
Air	-1000

Predefined threshold value	Minimum	Maximum
Bone (CT)	226	3071
Soft Tissue (CT)	-700	225
Enamel (CT, Adult)	1553	2850
Enamel (CT, Child)	2042	3071
Compact Bone (CT, Adult)	662	1988
Compact Bone (CT, Child)	586	2198
Spongial Bone (CT, Adult)	148	661
Spongial Bone (CT, Child)	156	585
Muscle Tissue (CT, Adult)	-5	135
Muscle Tissue (CT, Child)	-25	139
Fat Tissue (CT, Adult)	-205	-51
Fat Tissue (CT, Child)	-212	-72
Skin Tissue (CT, Adult)	-718	-177
Skin Tissue (CT, Child)	-766	-202

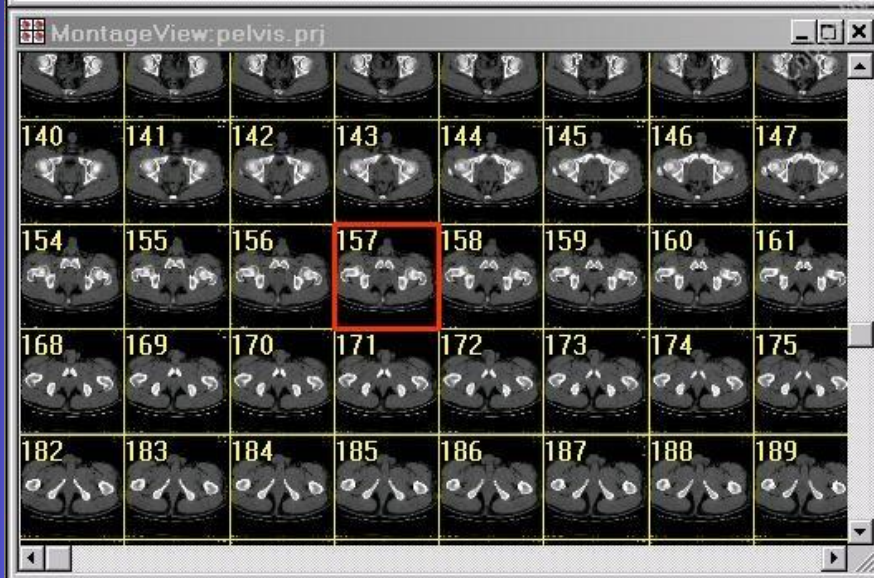

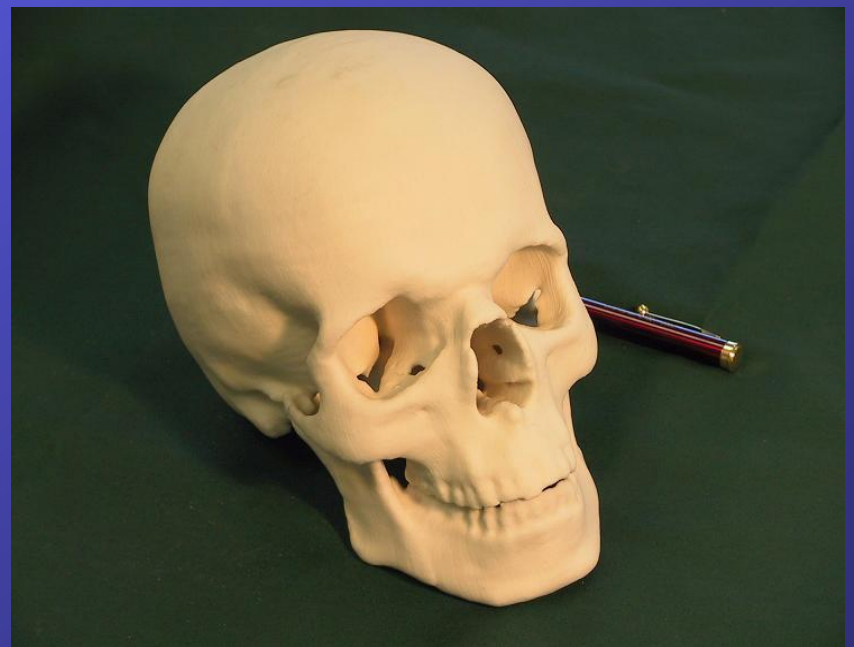
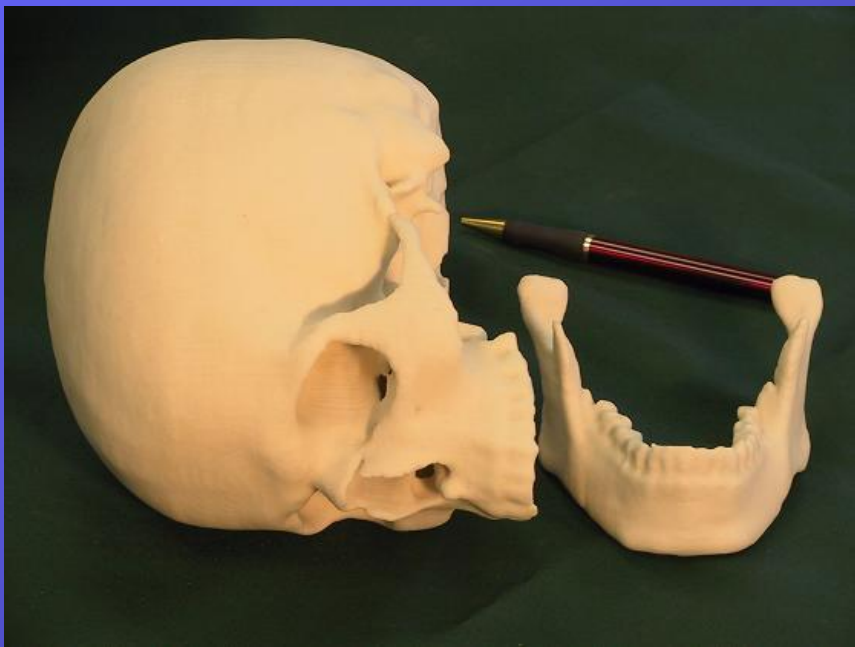
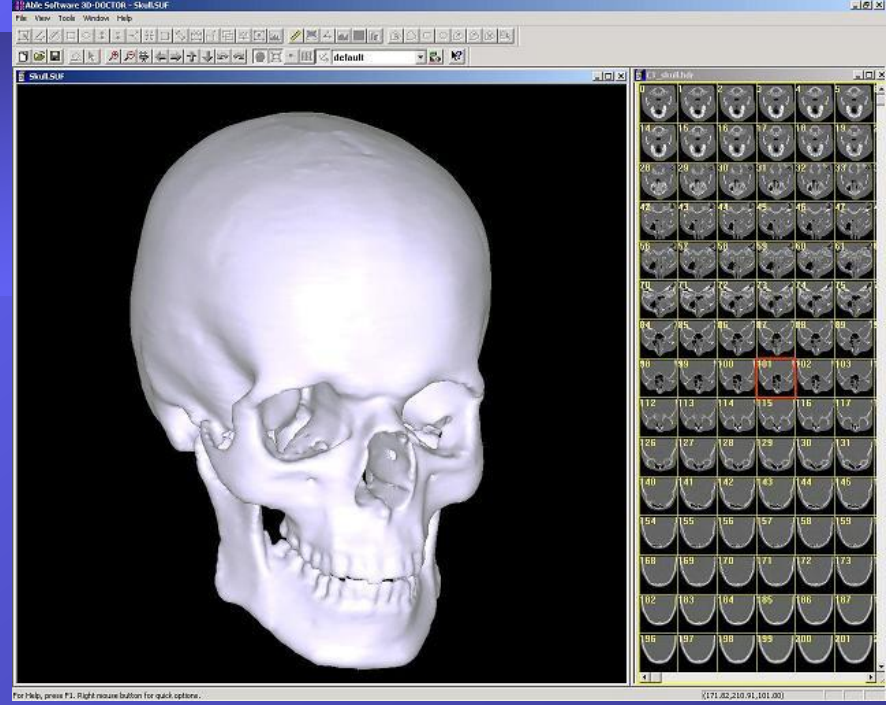
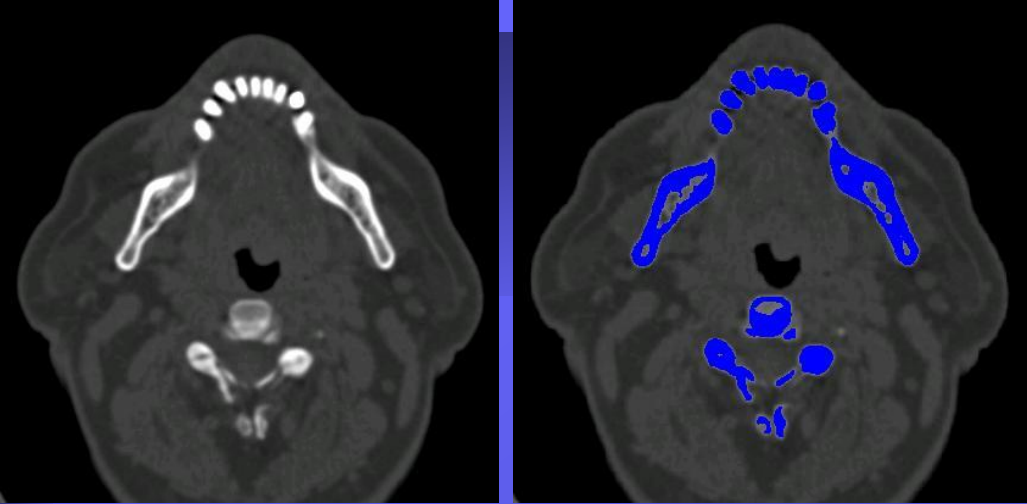

Prednosti

- ✓ Zahvaljujući relativno dobroj prodornosti X-zraka, kao i osetljivosti na gustinu materijala objekta, CT omogućava nedestruktivnu karakterizaciju i unutrašnjosti objekta.
- ✓ Zahvaljujući osobinama X-zraka, CT se podjednako dobro primenjuje na različitim materijalima (metal, plastika, organski materijali itd.), bilo glatkih ili teksturisanih površina, i to kako od solid (punih) tako i od vlaknastih materijala.
- ✓ CT je indiferentna na kvalitet obrađene površine.
- ✓ Ukupna geometrija objekta se dobija u samo jednom skenirajućem prolazu, čime se eliminise potreba za registracijom (uklapanjem) više oblaka tačaka.
- ✓ CT ne zahteva primenu pribora, a nije potrebno ni prethodno ni naknadno pomeranje objekta.

Prednosti

- ✓ Savremeni CT industrijski sistemi su dostigli nivo (preciznost i tačnost) da se mogu porediti sa KMM.
- ✓ Dve osnovne karakteristike CT skenera su rezolucija slika (tomograma) i energija X zraka.
- ✓ Rezolucija je funkcija debljine preseka, odnosno razmaka između dve uzastopne CT slike i kod novijih industrijskih skenera ona ide i ispod 10 μm.
- ✓ Izlazna digitalna informacija sada je dostupna u nekoliko standardnih formata za razmenu (IGES, STEP, STL itd.).
- ✓ Većina savremenih CT skenera sadrži i mogućnost integracije softvera za obradu CT informacija i kao rezultat daje kompletan 3D CAD model.

Nedostaci

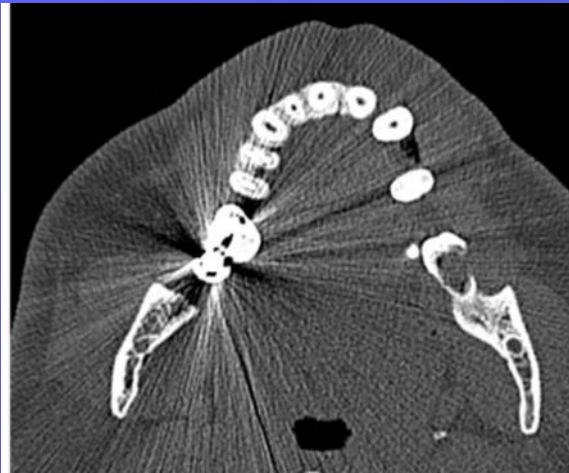

Problem šuma kod CBCT sistema

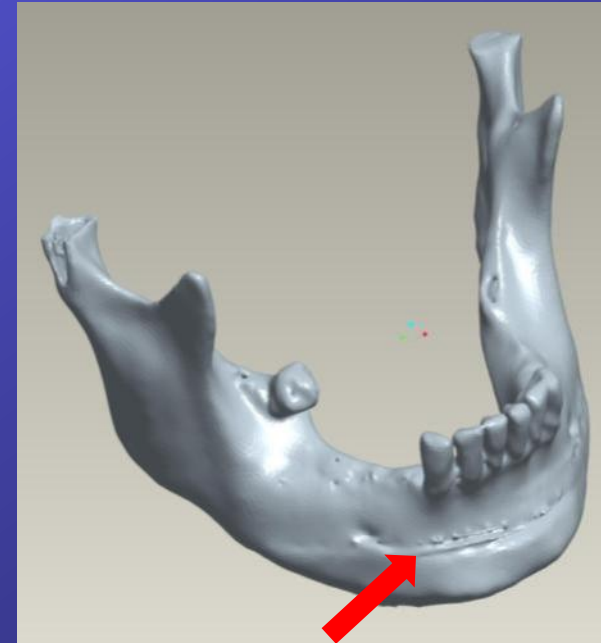
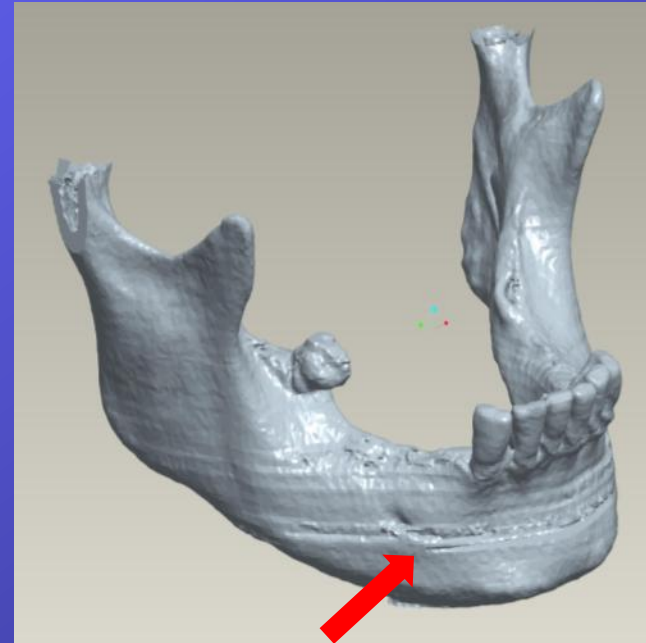
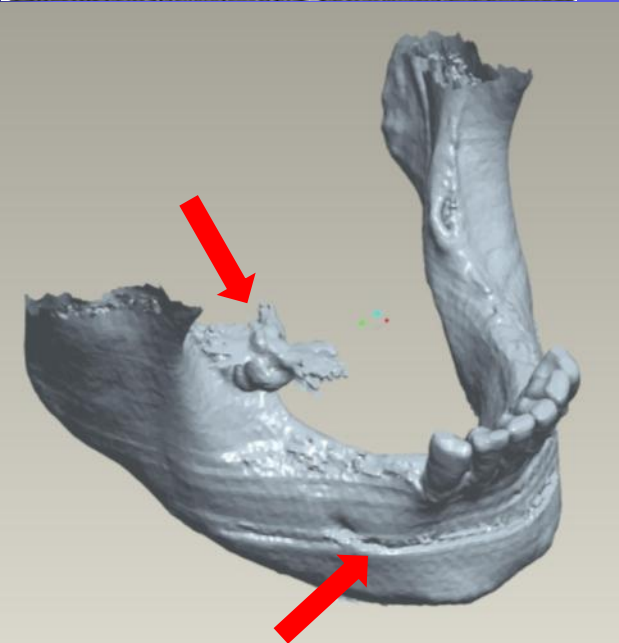
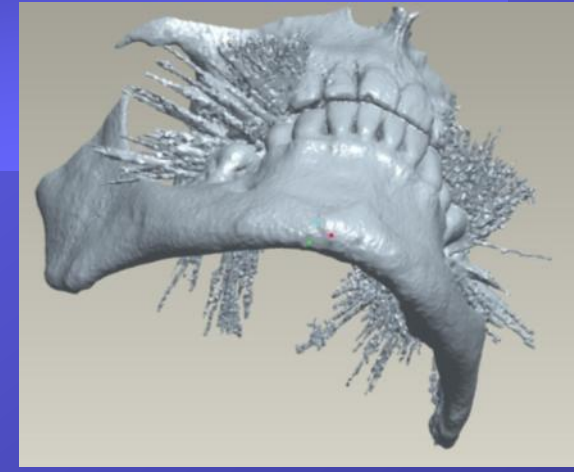
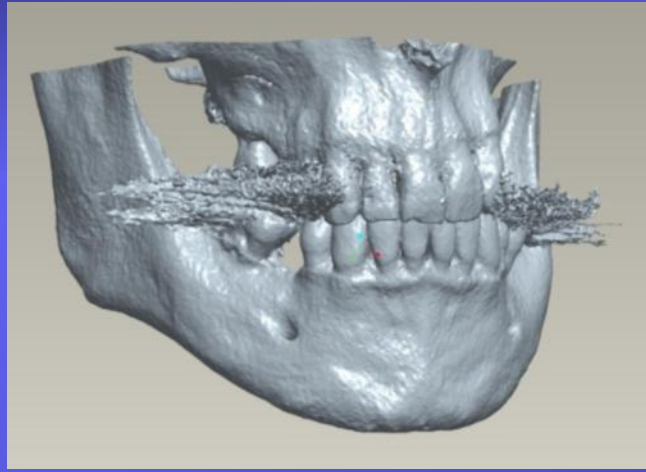
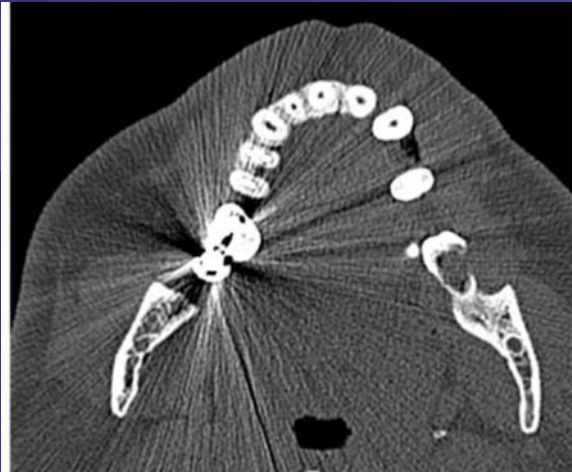

Model sa "šumom" od artefakata

Model očišćen od "šuma"

Model pripremljen za izradu

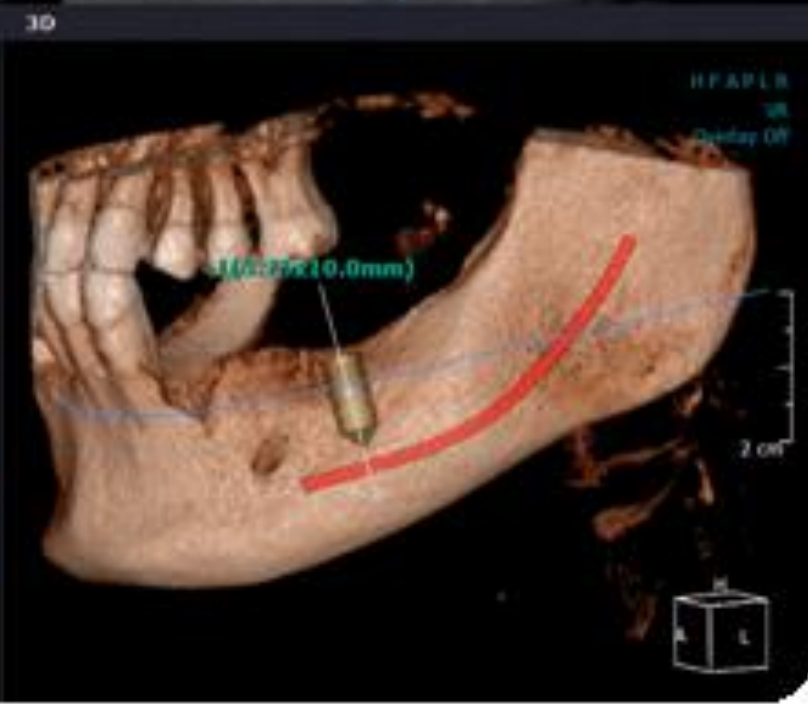
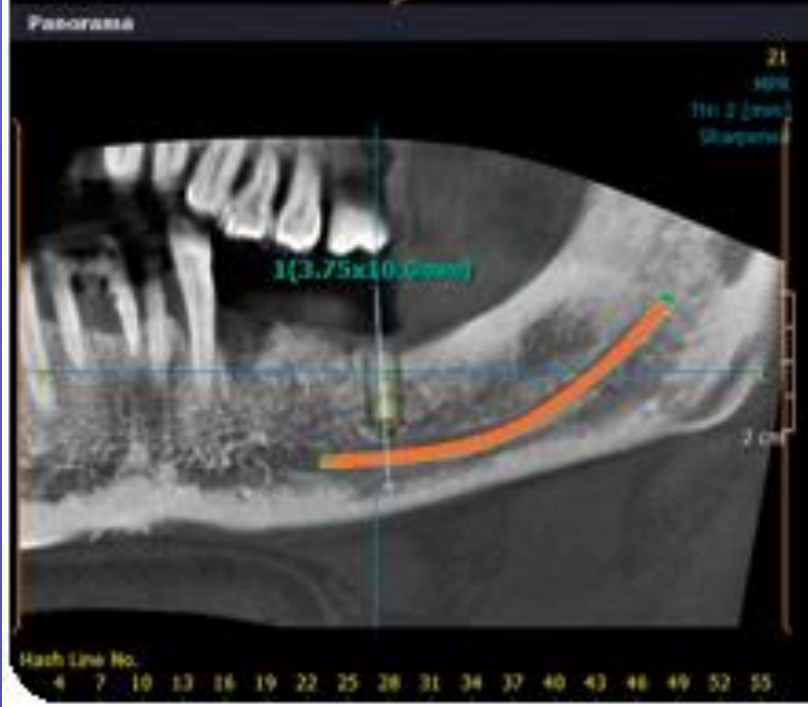
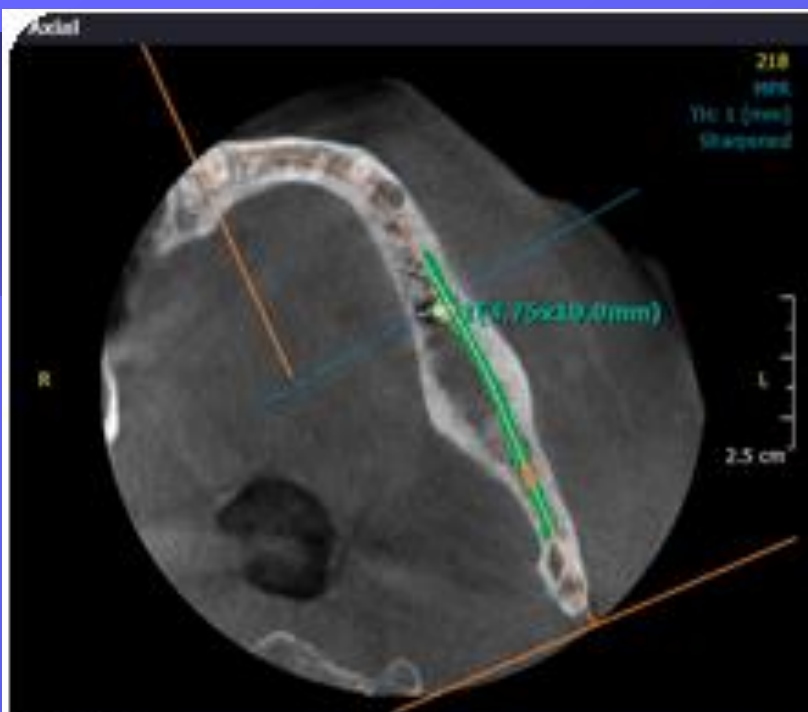

Primeri



Jabuka



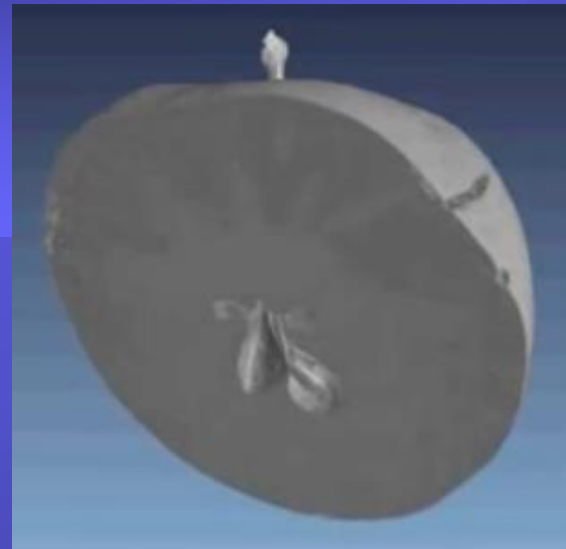

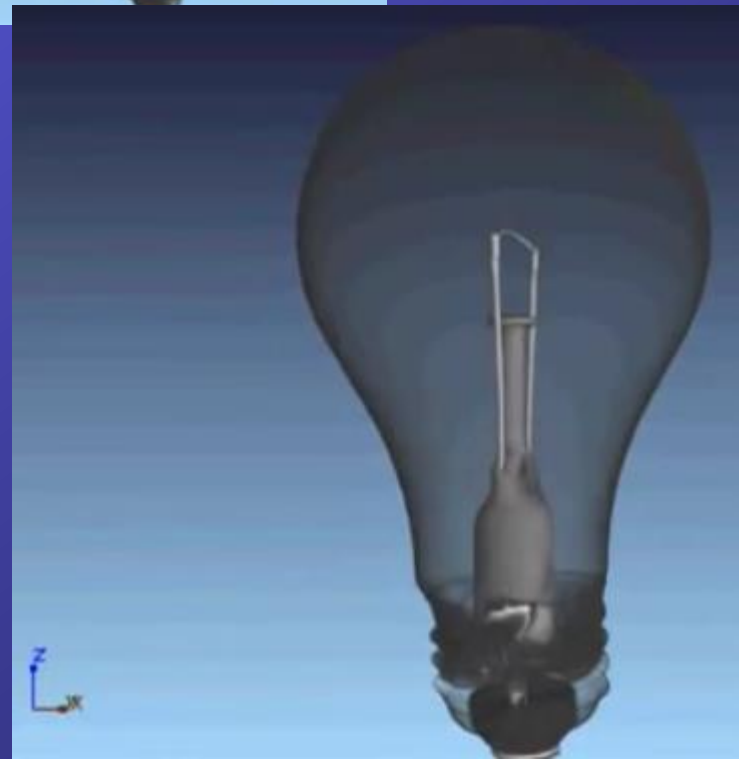
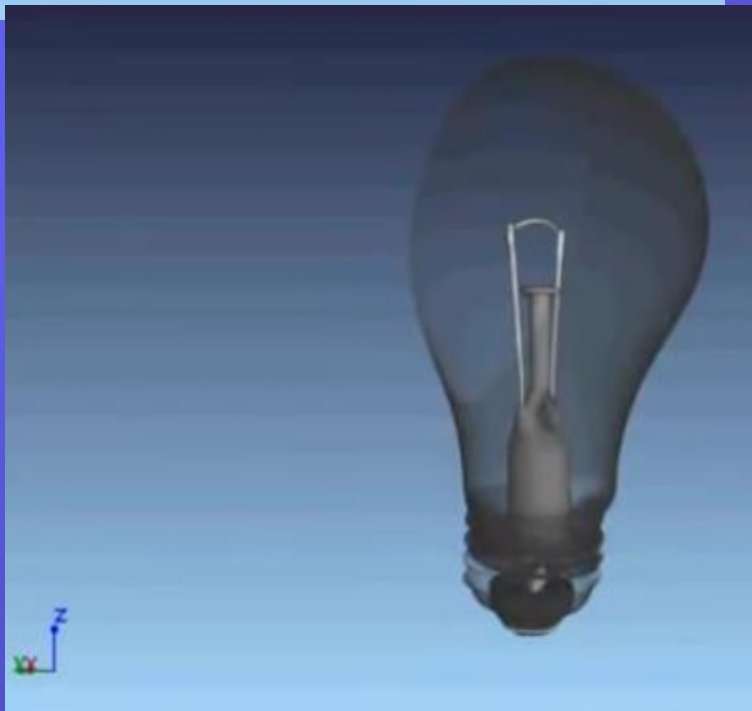

Sijalica

